

ARES

TABLE OF CONTENTS

English

Introduction.....	3
ARES Fence Options.....	4
I-Beam Installation.....	6
Level Bracket (EX-109) & Panel Installation.....	10
Angle Bracket (EXR-109) & Panel Installation.....	14
Panel Cutting.....	19
Notching & Trimming Rails.....	22
Care & Maintenance/ Warranty.....	24

INTRODUCTION

READ INSTRUCTIONS COMPLETELY BEFORE STARTING INSTALLATION

General Guidelines

It is the responsibility of the installer to meet all code and safety requirements, and to obtain all required building permits. The fencing installer should determine and implement appropriate installation techniques for each installation situation. Fortress Building Products and its distributors shall not be held liable for improper or unsafe installations.

Before You Begin

Contact your local Building Code Department for required permits and laws regarding your fence project.

Call 811 before you dig post holes to locate and identify any buried utilities.

These are typical instructions. Communications from the Engineer or Architect of record supersedes these typical instructions.

Note:

- When cutting Fortress Fencing, it is very important to complete the following at cut points:
- Remove all metal shavings from the cut area.
- File any sharp edges left by cutting. Thoroughly wipe and remove any filings, grime, or dirt.
- Apply two coats of Fortress zinc based touch-up paint to the cut area. If touch up is at rail ends, allow paint to dry before connecting bracket to I-Beam Post.
- Be sure to remove any metal shavings from the surface of Fence.

Required Tools



Goggles



Safety
Gloves



Tape
Measurer



Speed
Square



Level
Tool



Fortress
Touch-up Paint



Battery Operated
Impact Drill



Bit
Extender



N-30
Tri-Groove Socket



Drill Bit:
1/2" [12mm]



Spring
Punch



Rubber
Mallet



Ground
Stakes



Auger



String



Silver
Sharpie



Brush



Rags



Wheelbarrow



Shovel, Concrete
& Gravel



Reciprocating Saw
or Sawzall



Crane/
Forklift



Nylon
Straps

ARES FENCE OPTIONS

I-Beam Post

- ARES Fence I-Beam Post are available in 2 rail and 3 rail pre-punched options in lengths of 108" [2743mm], 120" [3048mm], 132" [3353mm], 144" [3658mm], 156" [3962mm], 168" [4267mm], 180" [4572mm], 192" [4877mm]. Each I-Beam Post is specific to panel height. For example, a 94" [2388mm] tall panel requires a corresponding post of 132" [3353mm].

Gate Uprights

- ARES Fence Gate Uprights are 2" [51mm] square, 12 gauge, which matches the height of the gate.

Panel & Gate Styles

- **C-Channel Rail** : 2-13/16" x 2-13/16" [71mm x 71mm], 11 Gauge
- **Gate Upright**: 2" [51mm], 11 Gauge
- **Pale**: 2-3/4" x 1" [70mm x 25mm], 14 Gauge
- **Slide Lock**: 19 Gauge
- **Air Space**: 3" [76mm]

Panel & Gate Options

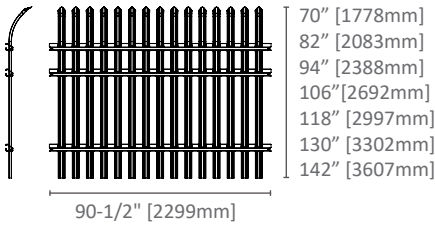

Citadel Panel

2 & 3 Rail options

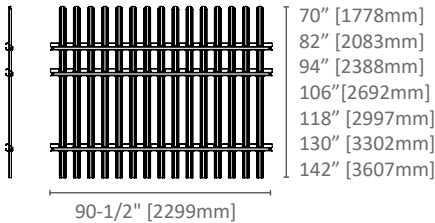

Scorpio Panel

2 & 3 Rail options

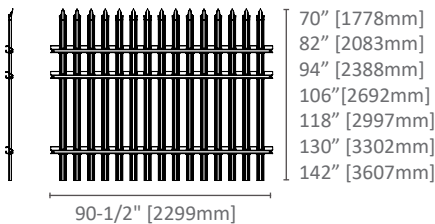

Spartan Panel

2 & 3 Rail options

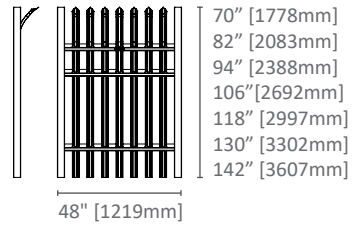

Citadel Walk Gate

2 & 3 Rail options

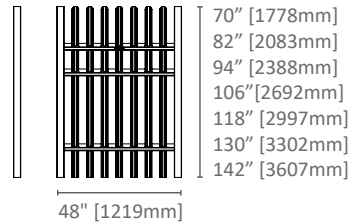

Scorpio Walk Gate

2 & 3 Rail options

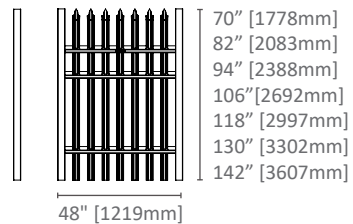

Spartan Walk Gate

2 & 3 Rail options

Bracket, Bolt & Nut Options

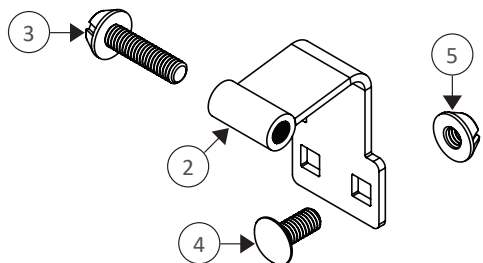
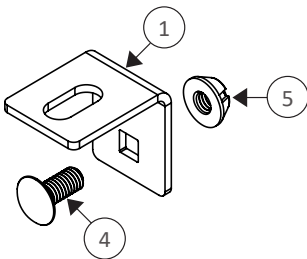

Component List

1. EX-109 Bracket
2. EXR-109 Bracket
3. 3/8" - 16 x 1-1/2" Thread Tri-Groove Bolt

4. 3/8" - 16 x 1" Square - Neck Carriage Bolt
5. 3/8" - 16 Thread Tri-Groove Nut

Note:

The N-30 Tri-groove socket is available for purchase from Fortress Building Products.

I-BEAM POST INSTALLATION

Step 1: Determine Desired I-Beam Post Spacing

1. Reference Fig. 1 below as well as the drawings provided by an architect or engineer as a guide for I-Beam Post spacing. **IT IS CRITICAL TO MAINTAIN THE PROVIDED SPACING FOR A SUCCESSFUL INSTALLATION.**

Note:

- I-Beam Post **maximum** on center spacing is 92" [2337mm].

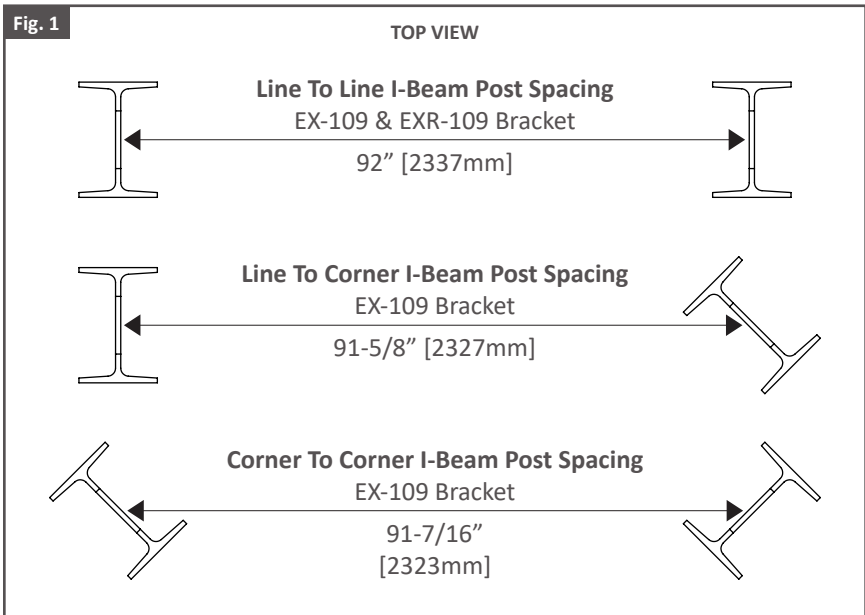

Step 2: Dig I-Beam Post Holes

1. Use an Auger to dig the post holes 39" [991mm] deep and 24" [610mm] in diameter. As shown in Fig. 2. Be sure to keep Auger straight and plumb.

Note:

- Call 811 before you dig post holes to locate and identify any buried utilities.
- Always consult local code requirements for exact post hole size.

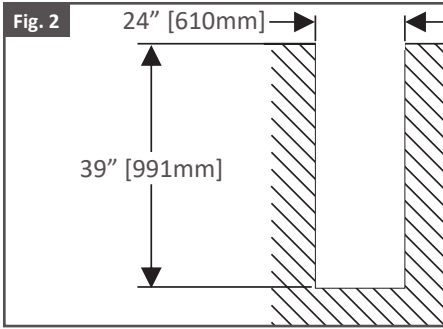

Step 3: Set I-Beam Posts into Footing Holes

1. Fill holes with 3" [72mm] of 3/4" [19mm] gravel or crushed stone to allow for drainage. As shown in Fig. 3.
2. Compact the gravel before setting post.
3. Use tape measure to check depth. ARES Fence posts are designed to be buried 36" [914mm] deep. As shown in Fig. 4.
4. Use the string as a guide when positioning an I-Beam Post into each hole. As shown in Fig. 5.

Note:

- Be sure the notched flange face of I-Beam is positioned to face the inside of the perimeter. As shown in Fig. 6.
- Be sure to account for slopes in ground surface when setting I-Beam Posts.

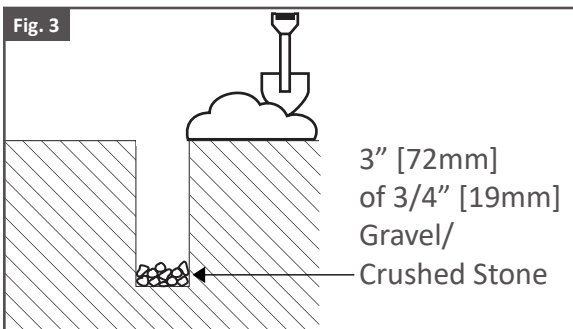

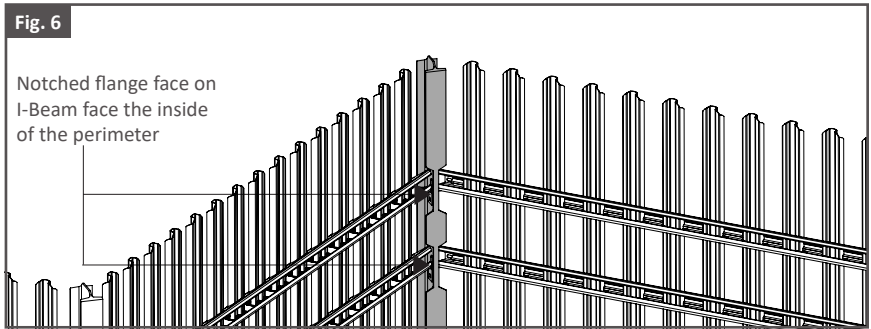
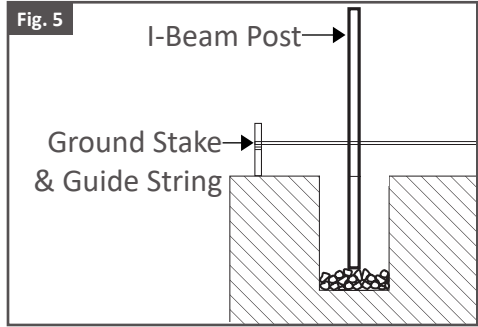
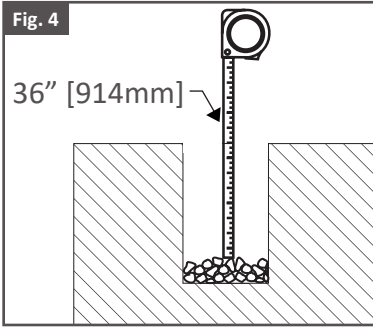

Step 4: Pour Concrete

1. **BEFORE POURING CONCRETE, CONFIRM THE I-BEAM POSTS ARE SPACED CORRECTLY AND SET AT CORRECT DEPTH. REFERENCE STEP 1 & 2.**
2. Fill post holes with concrete until the concrete is level with the grade.. As shown in Fig. 7.
3. Use a level to confirm that I-Beams are plumb, positioned with the desired spacing and aligned with the Guide Strings. Adjust as needed.

Tip:

- Fortress recommends the utilization of 5000psi concrete, unless otherwise specified by Architect or Engineer of record.
- Allow the concrete to cure for a minimum of 24 hours before installing Brackets and Panels.
- As the concrete cures, be sure to keep I-Beam Posts placed along guide strings & continuously check that they are plumb as well as in line with the next I-Beam Post and set at the desired spacing.

- If using EX-109 Brackets, confirm bracket locations are level before pouring concrete.

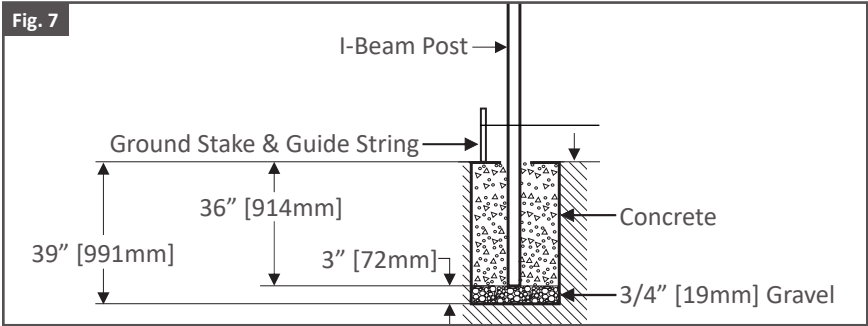

LEVEL BRACKET (EX-109) & PANEL INSTALLATION

ARES Level Assembly

Reference Bracket & Panel Options on page 5.

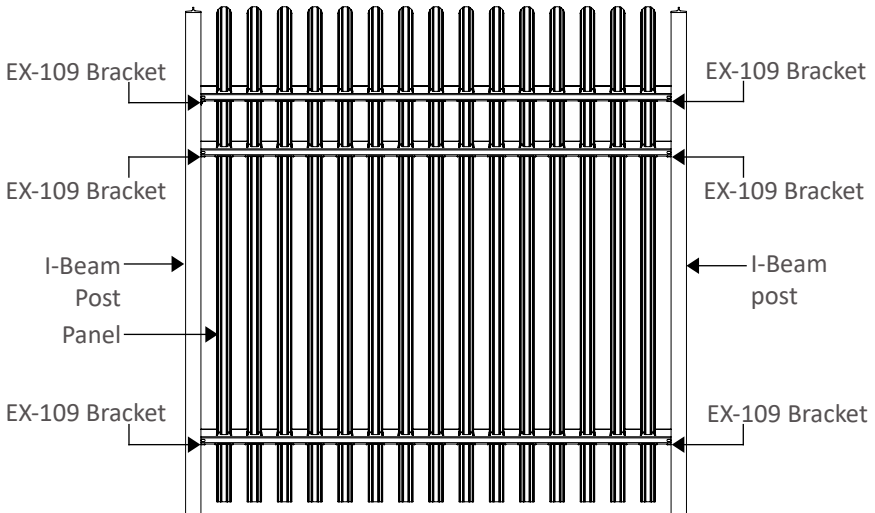

Step 1: Mount Level Brackets (EX-109) onto I-Beam

1. Position the EX-109 Brackets in desired position onto the I-Beam. As shown in Fig. 8 & 9.
2. Insert the 3/8" - 16 x 1" Square-Neck Carriage Bolt through the bracket and I-Beam bolt hole. As shown in Fig. 10.
3. Using the Tri-Groove Socket, fasten the 3/8" - 16 Thread Tri-Groove Nut onto the 3/8" - 16 x 1" Square-Neck Carriage Bolt. As shown in Fig. 11 & 12.
4. If mounting EX-109 Brackets onto both sides of an I-Beam, place brackets in desired position then fasten with the 3/8" - 16 x 1" Square-Neck Carriage Bolt and 3/8" - 16 Thread Tri-Groove Nut. As shown in Fig. 13 & 14.
5. Be sure Brackets are level before tightening bolts. Use a Rubber Mallet to level Brackets, if required.

Fig. 8

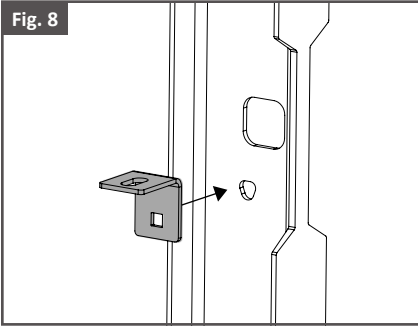

Fig. 9

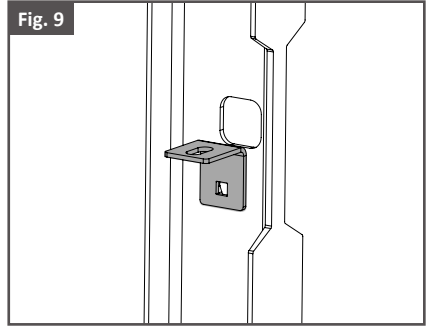

Fig. 10

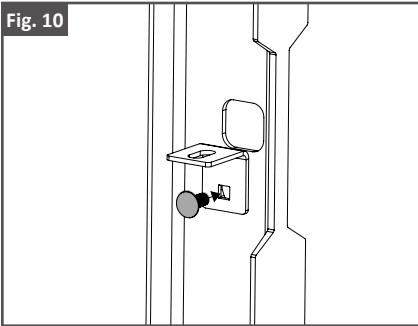

Fig. 11

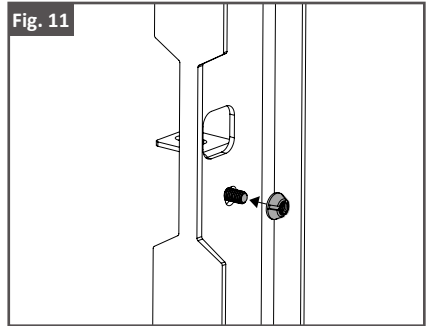

Fig. 12

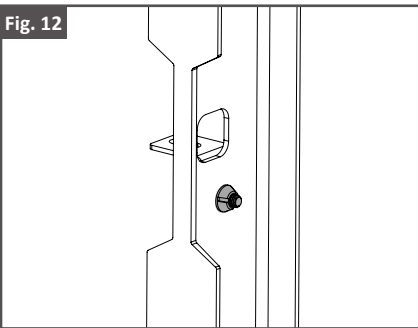

Fig. 13

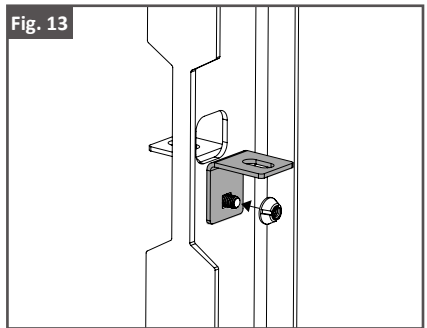
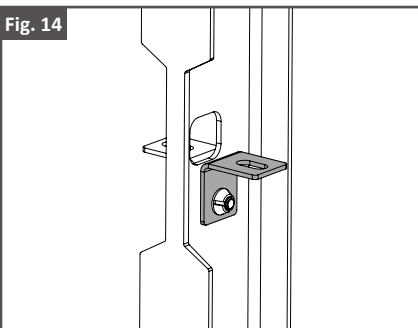

Fig. 14



Step 2: Mount Panel onto I-Beam Posts

1. Using a Crane or Forklift, position the Panel in desired position onto the mounted Brackets between I-Beam Posts. As shown in Fig. 15 & 16.
2. Be sure the Panel is positioned in the correct orientation between the I-Beam Post with the open side of the panel rails facing the inside of the fence perimeter. As shown in Fig. 17. Adjust in needed.
3. Confirm the Panel has a minimum air space of 2" [51mm] from the ground surface to the bottom of the panel.
4. Confirm the bolt holes on the bottom face of rails and brackets are aligned. As shown in Fig. 18. Adjust if needed.
5. Insert the 3/8" - 16 x 1" Square-Neck Carriage Bolt through panel and bracket bolt holes. As shown in Fig. 19.
6. Using the Tri-Groove Socket, fasten the 3/8" - 16 Thread Tri-Groove Nut onto the 3/8" - 16 x 1" Square-Neck Carriage Bolt. As shown in Fig. 20 & 21.

Note:

- **ARES panels are heavy. For installer safety, it is recommended to use a Crane or Forklift when installing.**

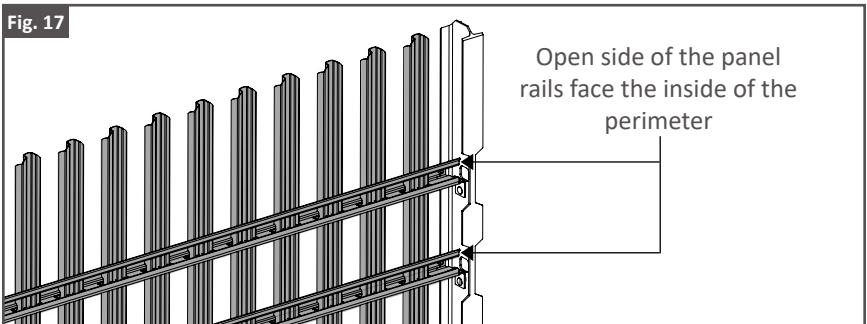
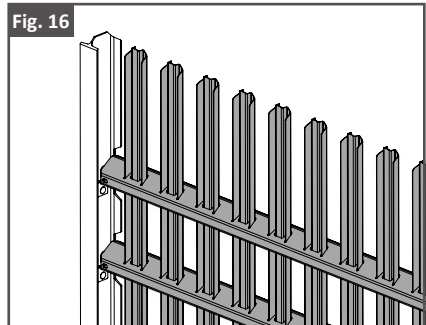
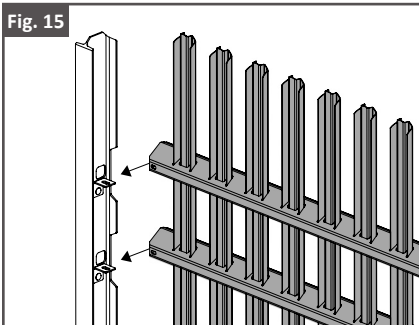

Fig. 18

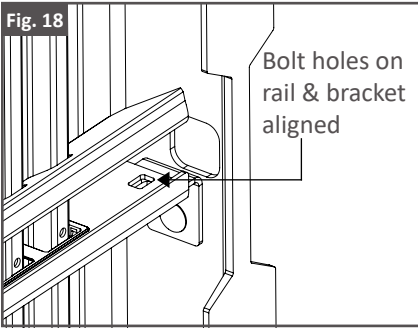

Fig. 19

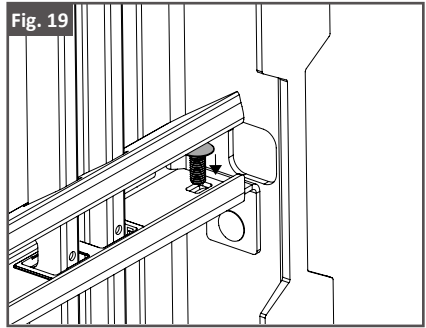

Fig. 20

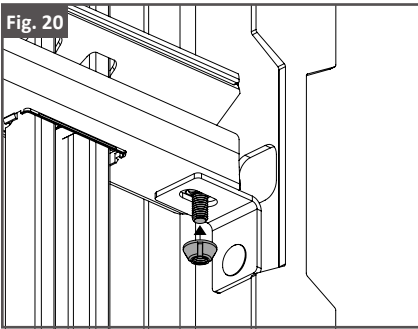
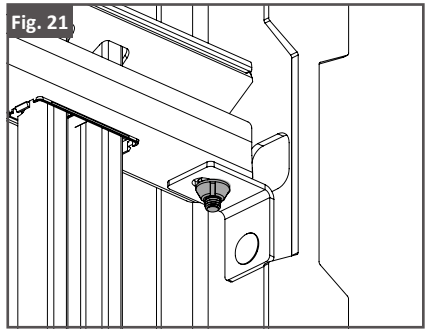

Fig. 21



ANGLE BRACKET (EXR-109) & PANEL INSTALLATION

ARES Angle Assembly

Reference Bracket & Panel Options on page 5.

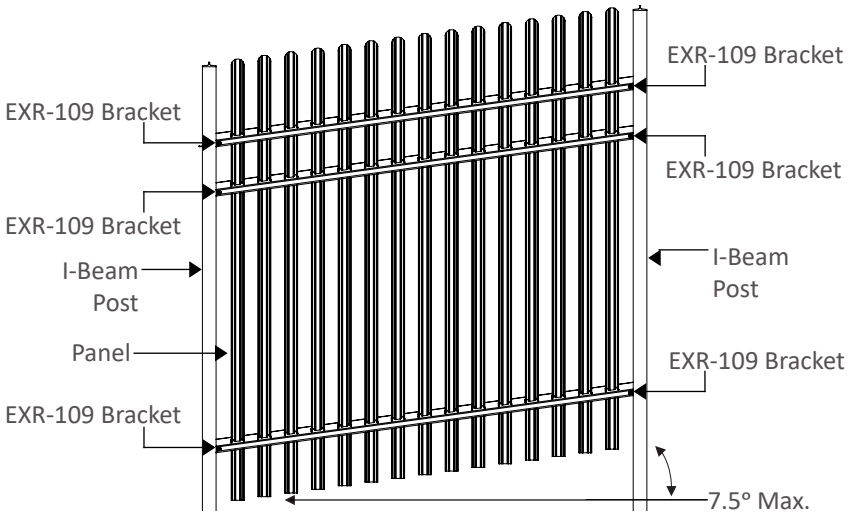

Step 1: Mount Angle Brackets (EXR-109) onto Ends of Panel

1. Using the Tri Groove Socket, fasten the 3/8" - 16 x 1-1/2" Thread Tri-Groove Bolt onto an ARES panel. As shown in Fig. 22 & 23.

Tip:

- **DO NOT** fully tighten the 3/8" - 16 x 1-1/2" Thread Tri-Groove Bolt in this step.

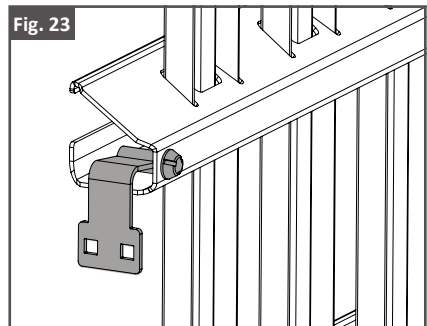
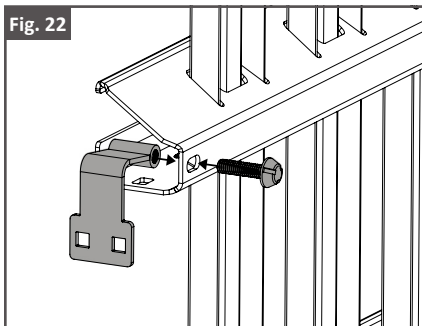

Step 2: Mount First Panel onto I-Beam Posts

1. Using a Crane or Forklift, position the first panel with mounted EXR-109 Brackets in desired position between the first two I-Beam Posts in fence run. As shown in Fig. 24 & 25.
2. Be sure the Panel is positioned in the correct orientation between the I-Beam post with the open side of the panel rails facing the inside of the fence perimeter. As shown in Fig. 26. Adjust if needed.
3. Confirm the panel has a minimum air space of 2" [51mm] from the ground surface to the bottom of the panel.
4. Begin mounting panel to the first I-Beam Post in run at connection points marked "1" in Fig. 27.
5. Insert a 3/8" - 16 x 1" Square-Neck Carriage Bolt through the bracket and I-Beam bolt hole. As shown in Fig. 28.
6. Using the Tri-Groove Socket, fasten the 3/8" - 16 Thread Tri-Groove Nut onto the 3/8" - 16 x 1" Square-Neck Carriage Bolt. As shown in Fig. 29 & 30.
7. Once panel is installed, the bracket **SHOULD NOT** block the square hole in the I-Beam Post. As shown in Fig. 31. Adjust if needed.
8. Rake the panel, then mount panel to the second I-Beam Post in run at connection points marked "2" in Fig. 27.
9. Insert a 3/8" - 16 x 1" Square-Neck Carriage Bolt through the bracket and I-Beam bolt hole. **DO NOT** fasten the 3/8" - 16 Thread Tri-Groove Nut onto the 3/8" - 16 x 1" Square-Neck Carriage Bolt in this step. As shown in Fig. 32 & 33.
10. Once panel is installed, the bracket **SHOULD NOT** block the square hole in the I-Beam Post. Adjust if needed.

Note:

- **ARES panels are heavy. For installer safety, it is recommended to use a Crane or Forklift when installing.**
- Lift panels at two locations, with equally spaced OSHA approved Nylon Straps.

Fig. 24

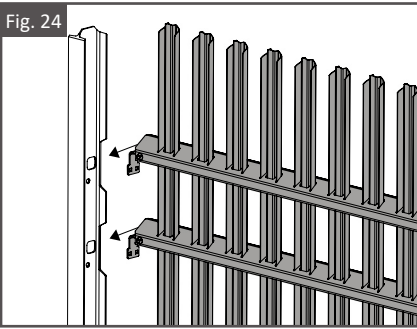

Fig. 25

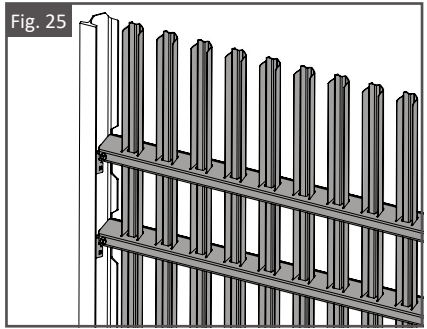

Fig. 26

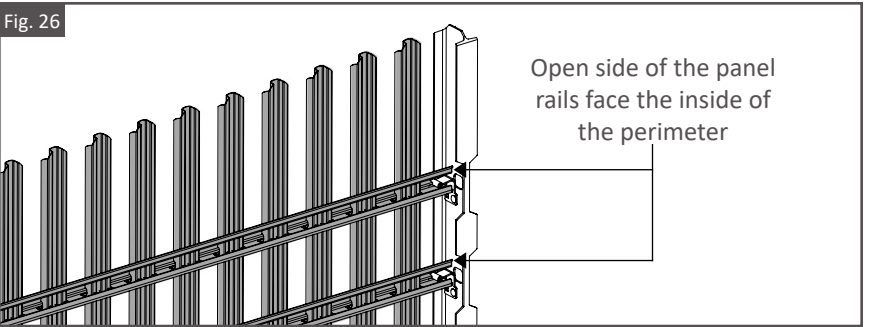

Fig. 27

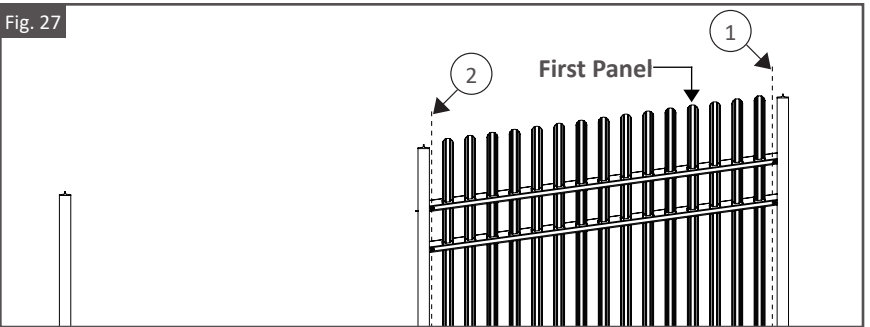

Fig. 28

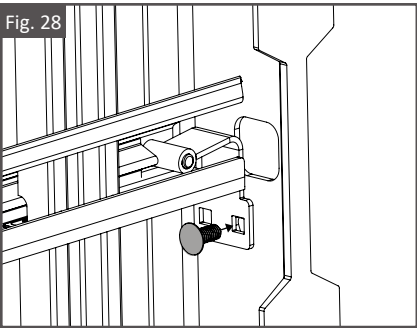
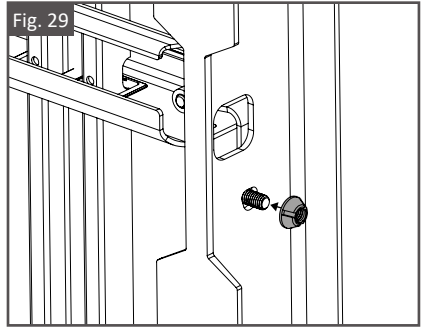
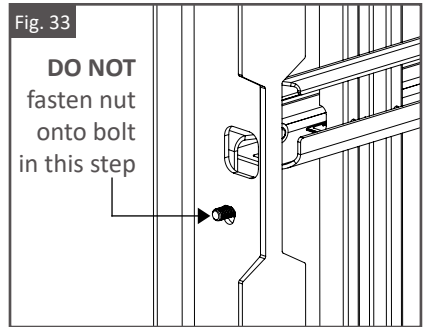
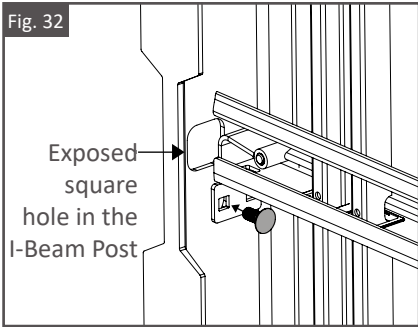
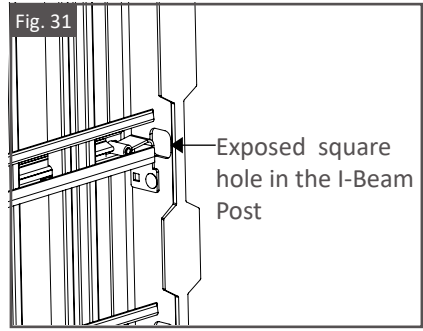
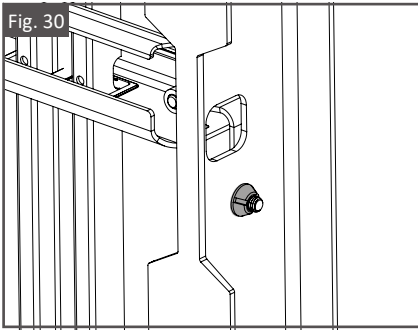

Fig. 29





Step 3: Mount Second Panel onto I-Beam Posts

1. Using a Crane or Forklift, position the second panel with mounted EXR-109 Brackets in desired position between the second and third I-Beam Posts in fence run. As shown in Fig. 34 & 35.
2. Be sure the Panel is positioned in the correct orientation between the I-Beam post with the open side of the panel rails facing the inside of the fence perimeter. As shown in Fig. 26 on page 16. Adjust if needed.
3. Confirm the panel has a minimum air space of 2" [51mm] from the ground surface to the bottom of the panel.
4. Begin mounting second panel to the second I-Beam Post in fence run at connection points marked "3" in Fig. 36.
5. Mount the second panel onto previously Inserted 3/8" - 16 x 1" Square-Neck Carriage Bolt through the bracket and I-Beam bolt hole. (Step 2: 9). As shown in Fig. 37.
6. Using the Tri-Groove Socket, fasten the 3/8" - 16 Thread Tri-Groove Nut onto the previously inserted 3/8" - 16 x 1" Square-Neck Carriage Bolt. As shown in Fig. 38 & 39.

7. Once panel is installed, the bracket **SHOULD NOT** block the square hole in the I-Beam Post. As shown in Fig. 31 on page 17. Adjust if needed.
8. Rake then mount panel to the third I-Beam Post in fence run at connection points marked “4” in Fig. 36.
9. If adding more panels to fence run, repeat steps 2: 9 & 10 on page 15 and step 3: 1 - 8 on pages 17 & 18.
10. If not adding more panels to fence run, repeat steps 2: 5 & 6 on page 15 to fasten second end of second panel onto the third I-Beam Post.
11. Once all panels in fence run are mounted, Use a Tri-Groove Socket to tighten all Tri-Groove Bolts.

Note:

- **ARES panels are heavy. For installer safety, it is recommended to use a Crane or Forklift when installing.**
- Recommended method of panel installation is to install starting with the top or highest I-Beam Post in fence run and work down to the bottom or lowest I-Beam Post.

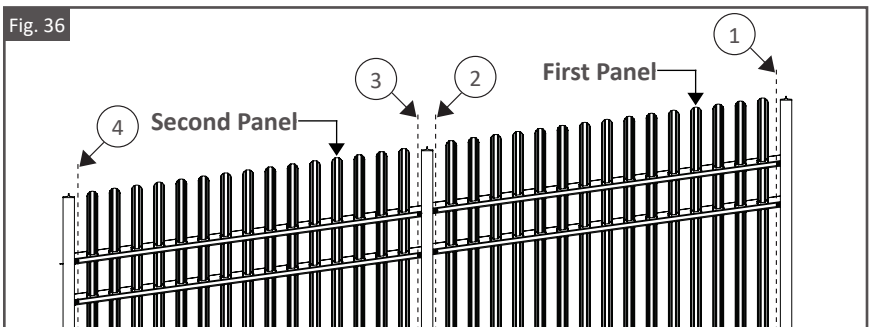
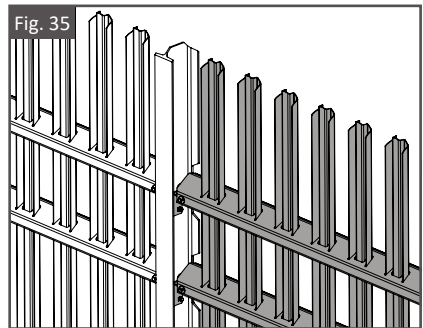
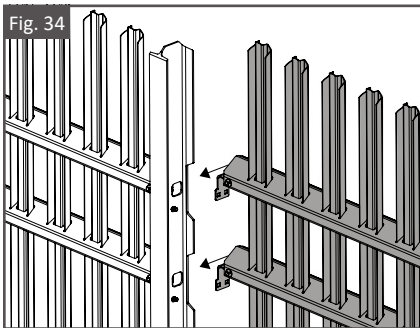

Fig. 37

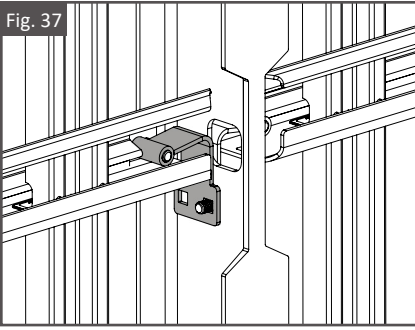

Fig. 38

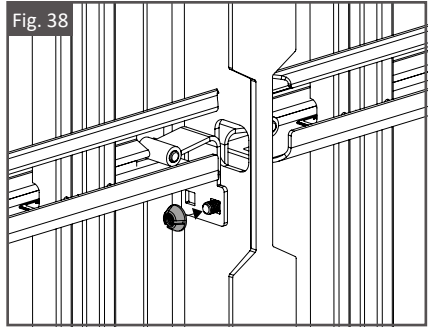
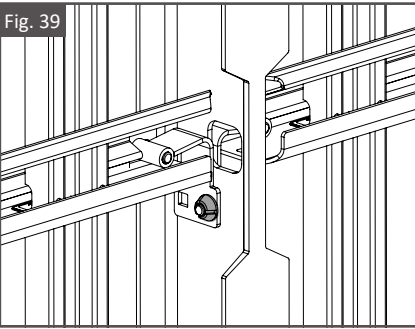

Fig. 39



PANEL CUTTING

Step 1: Measure The Panel Opening Length

1. Measure the distance of the Panel opening between the I-Beam Posts. Be sure to measure between the inside faces of the I-Beams. As shown in Fig. 40 & 41.

Tip:

- To ensure accurate spacing. Always measure this dimension at the lowest point of the I-Beam Post.
- Always design your layout to minimize the number of panels that need to be cut.

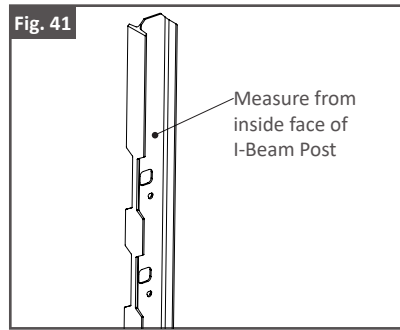
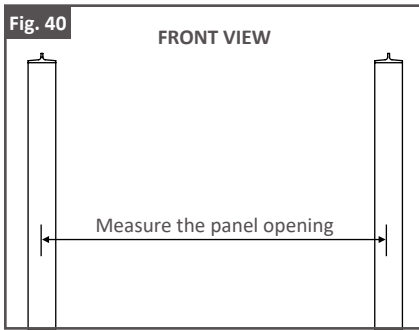

Step 2: Mark Panel with Cut Points

1. Minus 1-3/4" [45mm] from measured Panel opening length to account for the indent in I-Beam to allow panel to be inserted.
2. Use the determined length above as the cut Panel length.
3. Find the center of the Panel and measure out half of the previously determined length in each direction.
4. Mark the cut points with a Silver Sharpie on the rails of the Panel. As shown in Fig. 42. **Be sure cut marks are in line.**

Note:

- Before cutting the Panel, confirm the desired cut length **DOES NOT** interfere with the pickets.
- For a successful installation of the cut Panel, confirm the cut rail ends overhang a **minimum of 2" [51mm]** from the outer face of the end picket. As shown in Fig. 43. This length is required to notch the rail ends and drill bolt holes.

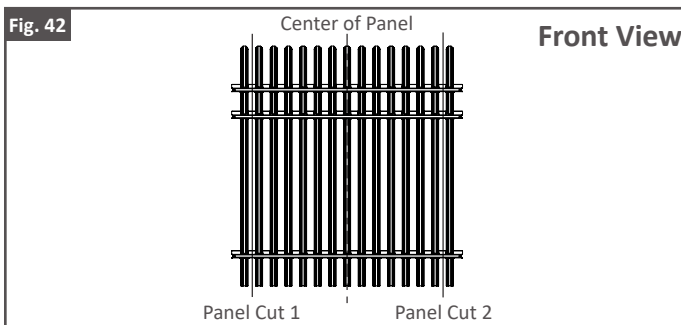

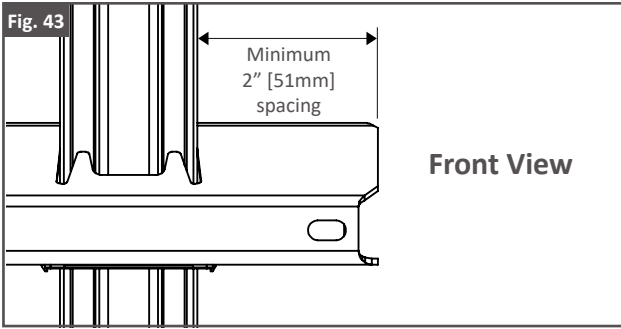

Step 3: Cut & Clean Panel

1. Cut the panel using a Reciprocating Saw or Sawzall. As shown in Fig. 44.
2. Use file to smooth cut edges. As shown in Fig. 45.
3. Remove any metal shavings and dust with a brush or rag. As shown in Fig. 46.
4. Be sure surfaces to be painted are clean.

Note:

- Fortress recommends to use a bi-metal blade when cutting panel rails.

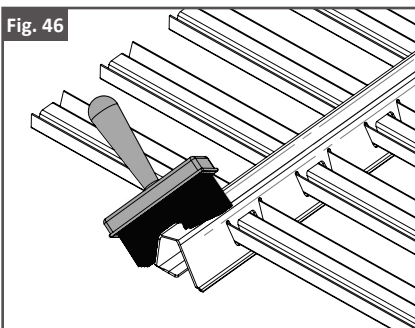
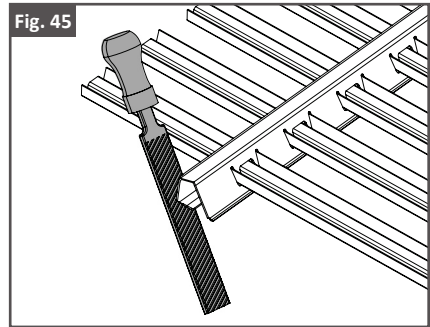
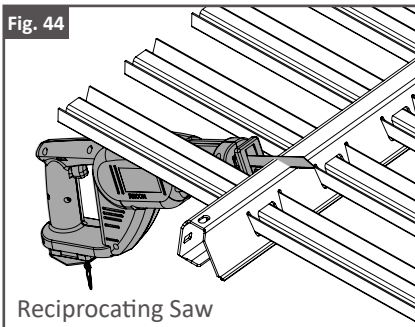

NOTCHING & TRIMMING RAILS

Step 1: Notch & Clean Rail Ends

1. Make cut marks on rail. Reference Fig. 47 for dimensions.
2. Cut rail ends using a Reciprocating Saw, Portable Band saw or Cutoff Wheel, then use a file to clean cuts.
3. Remove any metal shavings and dust with a brush or rag.

Note:

- Notched rails are required **ONLY** for corner installations. Notch on front of panel is for inside corner installation and notch on back of panel is for outside corner installation.

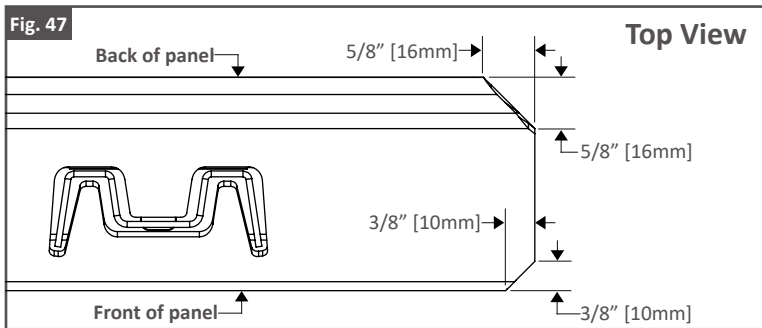

Step 2: Drill & Clean Bolt holes on Front Face of Rail Ends (EXR-109 Bracket)

1. Make cut marks on rail. Reference Fig. 48 for dimensions.
2. Drill bolt hole using a 1/2" [12mm] drill bit.
3. Use a file to clean cuts.
4. Remove any metal shavings and dust with a brush or rag.

Tip:

- Confirm angle bracket location before drilling bolt hole.

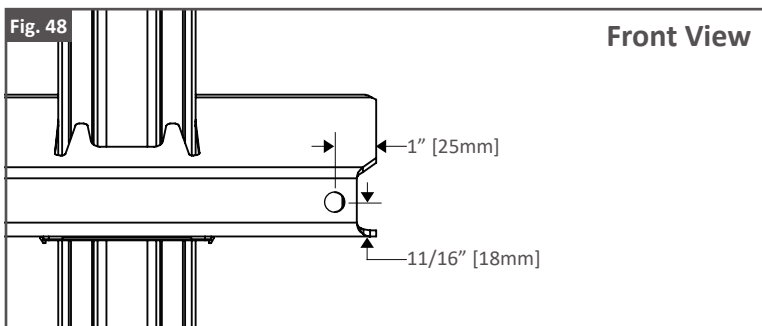

Step 3: Drill & Clean Bolt holes on Bottom Face of Rail Ends (EX-109 Bracket)

1. Make cut marks on rail. Reference Fig. 49 for dimensions.
2. Drill bolt hole using a 1/2" [12mm] drill bit.
3. Use a file to clean cuts.
4. Remove any metal shavings and dust with a brush or rag.

Tip:

- Confirm level bracket location before drilling bolt hole.

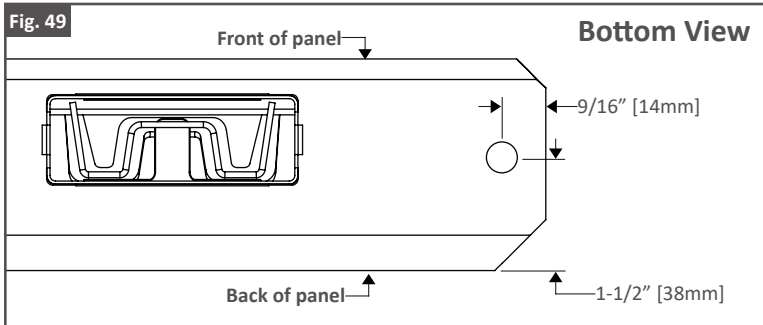

Step 4: Apply Spray Paint To Cut Areas

1. Using a piece of cardboard as a mask, apply the 1st coat of Fortress zinc based touch-up paint.
2. Allow to dry before applying second coat.
3. Apply the 2nd coat of Fortress zinc based touch-up paint.
4. Allow to dry and install.

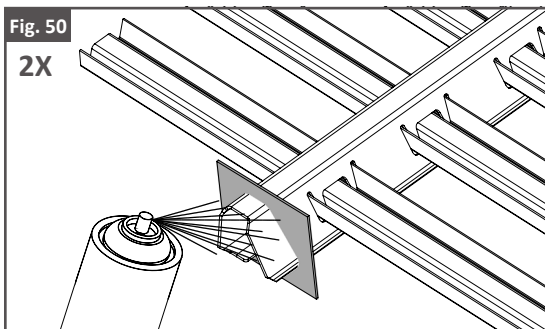

CARE & MAINTENANCE

Care And Maintenance Of Fortress Building Products Powder-Coated Products And Surfaces:

- Immediately after installation of your Fortress Building Products, clean powder-coated products and surfaces with a solution of warm water and non-abrasive, pH neutral detergent solution. Surfaces should be thoroughly rinsed after cleaning to remove all residues. All surfaces should be cleaned using a soft cloth or sponge.
- Ensure construction materials such as concrete, plaster, and paint splashes are removed immediately before they have a chance to dry. Failure to remove these materials may cause damage to the powder-coated surfaces.
- The frequency of cleaning depends in part on the standard of appearance and also the requirements to remove deposits that may cause damage to the powder coating after prolonged exposure. Fortress recommends cleaning in three to four monthly intervals all products and powder-coated
- **WARNING: Do not use strong solvents such as thinners, or solutions containing chlorinated hydrocarbons, esters, or ketones. Abrasive cleaners or cutting compounds should not be used.**

WARRANTY

To obtain and review a copy of the warranty, please go to: <https://Fortressbp.com/warranties>. You can also contact: (844) 909-1999 or write to: Fortress Building Products Warranty, 1720 N 1st St, Garland, TX 75040 to obtain a copy of the warranty.



JOIN THE REVOLUTION.

FortressBP.com | 866.323.4766