

Issue Date: 02-25-2014
Revision Date: 02-03-2025
Renewal Date: 02-28-2026

DIVISION: 05 00 00 - METALS
Section: 05 52 00 – Metal Railings

REPORT HOLDER:
Fortress Building Products
1720 North First Street
Garland, Texas 75040
972-231-4001
www.FortressRailing.com

REPORT SUBJECT:
Fe²⁶ Traditional Railing
Fe²⁶ PLUS Railing
Fe²⁶ Axis Railing

1.0 SCOPE OF EVALUATION

1.1 This Research Report addresses compliance with the following Codes:

- 2015 and 2012 *International Building Code*® (IBC)
- 2015 and 2012 *International Residential Code*® (IRC)

1.2 *Fe²⁶ Traditional Railing*, *Fe²⁶ PLUS Railing* and *Fe²⁶ Axis Railing* have been evaluated for the following properties (see Table 1):

- Durability

1.3 *Fe²⁶ Traditional Railing*, *Fe²⁶ PLUS Railing* and *Fe²⁶ Axis Railing* have been evaluated for the following uses (see Table 1):

- The *Fe²⁶ Traditional Railing*, *Fe²⁶ PLUS Railing* and *Fe²⁶ Axis Railing* as described in this report are guardrails under the definitions of the referenced Codes and are intended for use on elevated walking areas in buildings and walkways as required by the referenced Codes. See Table 1 for qualified guardrail dimensions.

2.0 STATEMENT OF COMPLIANCE

Fe²⁶ Traditional Railing, *Fe²⁶ PLUS Railing* and *Fe²⁶ Axis Railing* comply with the Codes listed in Section 1.1, for the properties stated in Section 1.2, and uses stated in Section 1.3, when installed as described in this report, including the Conditions of Use stated in Section 6.0.

3.0 DESCRIPTION

3.1 The *Fe²⁶ Traditional Railing*, *Fe²⁶ PLUS Railing* and *Fe²⁶ Axis Railing* systems are pre-assembled steel railing systems consisting of pre-galvanized formed steel rails, pickets, and posts (see Figure 1 through Figure 4). Systems consist of the following components:

3.1.1 The top and bottom rails of the *Fe²⁶ Traditional Railing* and *Fe²⁶ Axis Railing* are 1-inch square steel tubes. The *Fe²⁶ PLUS Railing* are 1.25-inch square steel tubes. See Figure 5.

3.1.2 The balusters of the *Fe²⁶ Traditional Railing* and the *Fe²⁶ PLUS Railing* are vertical 0.64 inch and 0.76-inch square steel tubes, respectively. See Figure 10. Balusters are permanently welded to top and bottom rails.

3.1.3 The balusters of the *Fe²⁶ Axis Railing* are horizontal 0.64-inch square steel tubes. See Figure 10. Balusters are pinned to rail end posts and permanently welded to an intermediate 1.00-inch-square vertical picket.

3.1.4 Top and bottom rails are connected to posts using metal mounting brackets. See Figure 6 through Figure 9.

3.1.5 The railings are attached to either conventional wood supports or steel post mounts of either: a) 2-inch square steel tube permanently welded to a 4-inch square steel base plate or b) 3-inch square steel tube permanently welded to a 5-1/8-inch square steel base plate. See Figure 11 and Figure 12. See Table 1 for configurations and Table 2 for fastening schedule.



4.0 PERFORMANCE CHARACTERISTICS

4.1 The *Fe²⁶ Traditional Railing*, *Fe²⁶ PLUS Railing* and *Fe²⁶ Axis Railing* systems described in this report have demonstrated the capacity to resist the design loads specified in Chapter 16 of the IBC, as well as Section R301 of the IRC when tested in accordance with ICC-ES AC273. The *Fe²⁶ Traditional Railing* and *Fe²⁶ Axis Railing* are limited to use in One- and Two-Family Dwellings.

5.0 INSTALLATION

5.1 *Fe²⁶ Traditional Railing*, *Fe²⁶ PLUS Railing* and *Fe²⁶ Axis Railing* must be installed in accordance with the manufacturer's published installation instructions, the applicable Code, and this Research Report. A copy of the manufacturer's instructions must be available on the jobsite during installation.

5.2 *Fe²⁶ Traditional Railing*, *Fe²⁶ PLUS Railing* and *Fe²⁶ Axis Railing* are pre-assembled steel railing systems.

5.3 Top and bottom rails are secured to steel support posts or conventional 4x4 wood posts with metal brackets and stainless steel screws. The wood in the supports and supporting structure shall have a specific gravity of 0.55 or greater (Southern Yellow Pine or better) and a minimum thickness to allow full penetration of the mounting screws. The steel support post shall have the minimum wall thickness indicated in Figure 11. Rail attachment shall be in accordance with Table 2.

5.4 The steel post mounts are anchored to a concrete or steel surface with four 3/8-inch approved anchor bolts. The type and length of the anchor bolts is dependent upon the material and condition of the supporting structure and is not within the scope of this report. See Section 6: Conditions of Use for additional requirements.

6.0 CONDITIONS OF USE

6.1 Installation must comply with this Research Report, the manufacturer's published installation instructions, and the applicable Code. In the event of a conflict, this report governs.

6.2 Conventional wood guardrail supports, including 4x4 posts, and framing are not within the scope of this report and are subject to evaluation and approval by the building official. Supports must satisfy the design load requirements specified in Chapter 16 of the IBC. Supports and framing must provide suitable material for anchorage of the rail brackets and supports, respectively. Where required by the building official, engineering calculations and details shall be provided.

6.3 Steel guardrail supports were evaluated for use in steel or concrete applications and are described in Section 3.1.5.

6.4 Concrete anchors and anchoring systems for use with the steel post mounts are not within the scope of this report and are subject to evaluation and approval by the building official. Anchors must satisfy the design load requirements specified in Chapter 16 of the Building Code and must meet the following minimum requirements:

6.4.1 A minimum of four anchor bolts must be used and located in the four pre-drilled holes in the post base plate.

6.4.2 The anchors must be stainless steel, galvanized steel, or other approved material compatible with the steel post mount system.

6.4.3 The anchor bolts must have a minimum diameter of 3/8 inch and utilize flat washers. The type and length of the anchor bolts is dependent upon the material and condition of the supporting structure and is not within the scope of this report.

6.4.4 Where required by the building official, engineering calculations and details shall be provided. The calculations shall verify that the anchorage and supporting structure complies with the Building Code for the type and condition of the supporting construction.

6.4.5 Any component or configuration not identified in this report has not been evaluated for performance and/or compliance to the referenced Codes. Identification of such components with the CCRR program mark and/or number is prohibited.





6.4.6 Only those types of fasteners and fastening methods described in this report have been evaluated for the installation of the railing systems described herein; other methods of attachment are outside the scope of this report.

6.5 The *Fe²⁶ Traditional Railing*, *Fe²⁶ PLUS Railing* and *Fe²⁶ Axis Railing* are manufactured under a quality control program with inspections by Intertek Testing Services NA, Inc.

7.0 SUPPORTING EVIDENCE

7.1 Manufacturer's drawings and installation instructions.

7.2 Reports of testing and engineering analysis demonstrating compliance with the performance requirements of ICC-ES AC273, *Acceptance Criteria for Handrails and Guards*, revised March 2016.

7.3 Documentation of an Intertek approved quality control system for the manufacturing of products recognized in this report.

8.0 IDENTIFICATION

Fe²⁶ Traditional Railing, *Fe²⁶ PLUS Railing* and *Fe²⁶ Axis Railing* are identified with the manufacturer's name (Fortress Building Products), address and telephone number, the product name (*Fe²⁶ Traditional Railing*, *Fe²⁶ PLUS Railing*, or *Fe²⁶ Axis Railing*), the statement "See CCRR-0192 at

<https://bpdirectory.intertek.com> for uses and performance levels," the statement "For use in one- and two-family dwellings only," where applicable, the Intertek Mark as shown below, and the Code Compliance Research Report number (CCRR-0192).



9.0 OTHER CODES

This section is not applicable.

10.0 CODE COMPLIANCE RESEARCH REPORT USE

10.1 Approval of building products and/or materials can only be granted by a building official having legal authority in the specific jurisdiction where approval is sought.

10.2 Code Compliance Research Reports shall not be used in any manner that implies an endorsement of the product by Intertek.

10.3 Reference to the <https://bpdirectory.intertek.com> is recommended to ascertain the current version and status of this report.

This Code Compliance Research Report ("Report") is for the exclusive use of Intertek's Client and is provided pursuant to the agreement between Intertek and its Client. Intertek's responsibility and liability are limited to the terms and conditions of the agreement. Intertek assumes no liability to any party, other than to the Client in accordance with the agreement, for any loss, expense or damage occasioned by the use of this Report. Only the Client is authorized to permit copying or distribution of this Report and then only in its entirety, and the Client shall not use the Report in a misleading manner. Client further agrees and understands that reliance upon the Report is limited to the representations made therein. The Report is not an endorsement or recommendation for use of the subject and/or product described herein. This Report is not the Intertek Listing Report covering the subject product and utilized for Intertek Certification and this Report does not represent authorization for the use of any Intertek certification marks. Any use of the Intertek name or one of its marks for the sale or advertisement of the tested material, product or service must first be approved in writing by Intertek.





TABLE 1 – QUALIFIED LEVEL GUARDRAIL SYSTEMS

Railing System	Maximum Guardrail Dimensions ⁽¹⁾	Railing Brackets	Substrate for Railing Bracket	Code Occupancy Classification
<i>Fe²⁶</i> Traditional Railing (Level)	93-1/2" x 36" ⁽²⁾ 93-1/2" x 42"	CB-04 Bracket -or- UB-04 Universal Bracket	2" Steel Post Mount ⁽³⁾ -or- Conventional 4x4 Wood Post	IRC: One- and Two-Family Dwellings
<i>Fe²⁶</i> Traditional Railing (Stair)	93-1/2" x 37"	SSB-04 Simplified Stair Bracket	2" Steel Post Mount ⁽³⁾	IRC: One- and Two-Family Dwellings
<i>Fe²⁶</i> PLUS Railing (Level)	93-1/2" x 36" ⁽²⁾	CB-05 Collar Bracket	3" Steel Post Mount ⁽³⁾ -or- Conventional 4x4 Wood Post	IRC: One- and Two-Family Dwellings
<i>Fe²⁶</i> PLUS Railing (Level)	93-1/2" x 42"	UB-05 Universal Bracket	3" Steel Post Mount ⁽³⁾ -or- Conventional 4x4 Wood Post	IBC: All Use Groups
<i>Fe²⁶</i> Axis Railing (Level)	93-7/8" x 42"	UB-04 Universal Bracket	2" Steel Post Mount ⁽³⁾ -or- Conventional 4x4 Wood Post	IRC: One- and Two-Family Dwellings
<i>Fe²⁶</i> Axis Railing (Stair)	93-1/2" x 42"	SSB-04 Simplified Stair Bracket	2" Steel Post Mount ⁽³⁾	IRC: One- and Two-Family Dwellings

- ⁽¹⁾ Level rail lengths are maximum clear length between supports. Railing height is the minimum installed height from walking surface to top of top rail.
- ⁽²⁾ The use of these products shall be limited to exterior use as a guard system for balconies and porches for one- and two-family dwellings in accordance with the IRC.
- ⁽³⁾ Installation on surface of steel or concrete only.



TABLE 2 – FASTENING SCHEDULE

Railing System	Railing Brackets	Connection	Fastener	Qty.
<i>Fe²⁶</i> Traditional Railing	CB-04 Collar Bracket	Rail Bracket to Steel Support ⁽¹⁾	#12-24 by 3/4" Torx drive, flat head, Type F thread cutting point, stainless steel screws	2
		Rail Bracket to Conventional 4x4 Wood Post	#12-10 by 2-1/2" Torx drive, flat-head, type A point steel screws	2
		Rail Bracket to Rail ^{(1) (2)}	#12-24 by 3/4" Torx drive, flat head, Type F thread cutting point, stainless steel screw	1
	UB-04 Universal Bracket	Rail Bracket to Steel Support ⁽¹⁾	#12-24 by 3/4" Torx drive, flat head, Type F thread cutting point, stainless steel screws	2
		Rail Bracket to Conventional 4x4 Wood Post	#12-10 x 2-1/2-inch stainless steel, Torx drive, flat-head wood screw	2
		Rail Bracket to Rail ⁽²⁾	#12-24 by 3/4" Torx drive, flat head, Type F thread cutting point, stainless steel screw	1
<i>Fe²⁶</i> Traditional Railing (Stair)	SSB-04 Simplified Stair Bracket	Rail Bracket to steel Post	#12-24 by 3/4" Torx drive, flat head, Type F thread cutting point, stainless steel screws	2
		Rail Bracket to Rail	#12-24 by 3/4" Torx drive, flat head, Type F thread cutting point, stainless steel screws	1
<i>Fe²⁶</i> PLUS Railing	UB-05, and CB-05 Collar Bracket	Rail Bracket to to Steel Post	#12-24 by 3/4 in, Torx drive, flat-head, Type F thread cutting point, steel screws	2
		Rail Bracket to Steel Post	#12-24 by 3/4" Torx drive, flat head, Type F thread cutting point, stainless steel screws	2
		Rail Bracket to Conventional 4x4 Wood Post	#12-10 x 2-1/2-inch stainless steel, Torx drive, flat-head wood screw	2
		Rail Bracket to Rail ⁽²⁾	#12-24 by 3/4" Torx drive, flat head, Type F thread cutting point, stainless steel screw	1

⁽¹⁾ Pre-drill a 3/16-inch diameter hole

⁽²⁾ Located on the protected side of the deck (i.e. facing the walking surface)



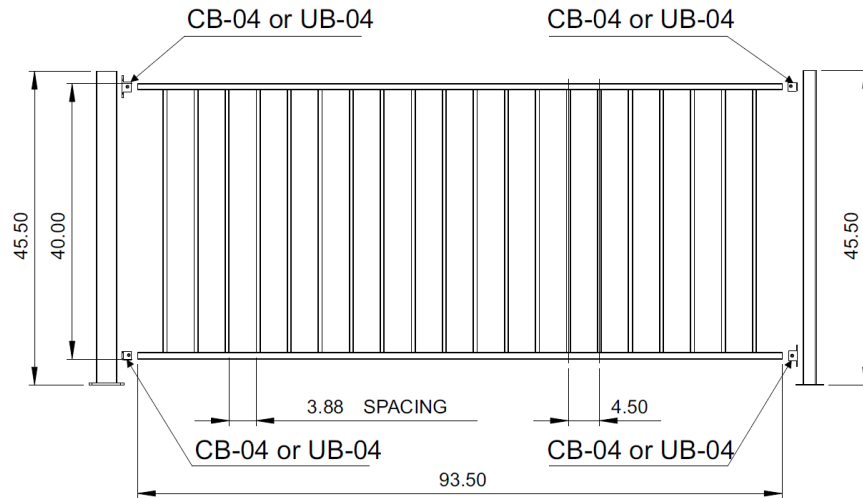

TABLE 2 – FASTENING SCHEDULE (CONTINUED)

Railing System	Railing Brackets	Connection	Fastener	Qty.
<i>Fe²⁶</i> Axis Railing	UB-04 Universal Bracket	Rail Bracket to Steel Support ⁽¹⁾	#10-24 by 3/4" Torx drive, flat head, Type F thread cutting point, stainless steel screws	2
		Rail Bracket to Conventional 4x4 Wood Post	#10-10 x 2-1/2-inch stainless steel, Torx drive, flat-head wood screw	2
		Rail Bracket to Rail End Frame ⁽²⁾	#10-24 by 3/4" Torx drive, flat head, Type F thread cutting point, stainless steel screw	1
	N/A	Infill Panel Top/Bottom Rail to Rail End Frame ⁽²⁾	#10-24 by 1/2" Torx drive, flat head, Type F thread cutting point, stainless steel screw	1
	N/A	Horizontal Picket to Rail End Frame	Compression Plug	1
	N/A	Horizontal Picket to Intermediate Vertical Baluster	Tack Weld	2
<i>Fe²⁶</i> Axis Railing (Stair)	SSB-04 Simplified Stair Bracket	Rail Bracket to steel Post ⁽¹⁾	#10-24 by 3/4" Torx drive, flat head, Type F thread cutting point, stainless steel screws	2
		Hinge Bracket Assembly	1-1/4-inch long two-piece binding bolt with #8-32 by 1/4" pan head screw	1
		Rail Bracket to Rail End Frame	#10-24 by 3/4" Torx drive, flat head, Type F thread cutting point, stainless steel screws	1
	N/A	Infill Panel Top/Bottom Rail to Rail End Frame ⁽²⁾	#10-24 by 1/2" Torx drive, flat head, Type F thread cutting point, stainless steel screw	1
	N/A	Horizontal Picket to Rail End Frame	Compression Fit to Hinge Pin	1
	N/A	Horizontal Picket to Intermediate Vertical Baluster	Hinge Pin	1

⁽¹⁾ Pre-drill a 3/16-inch diameter hole

⁽²⁾ Located on the protected side of the deck (i.e. facing the walking surface)



**FIGURE 1 – 40" Fe²⁶ TRADITIONAL LEVEL RAILING ASSEMBLY
TYPICAL WITH Fe²⁶ PLUS USING CB-05 COLLAR BRACKETS**

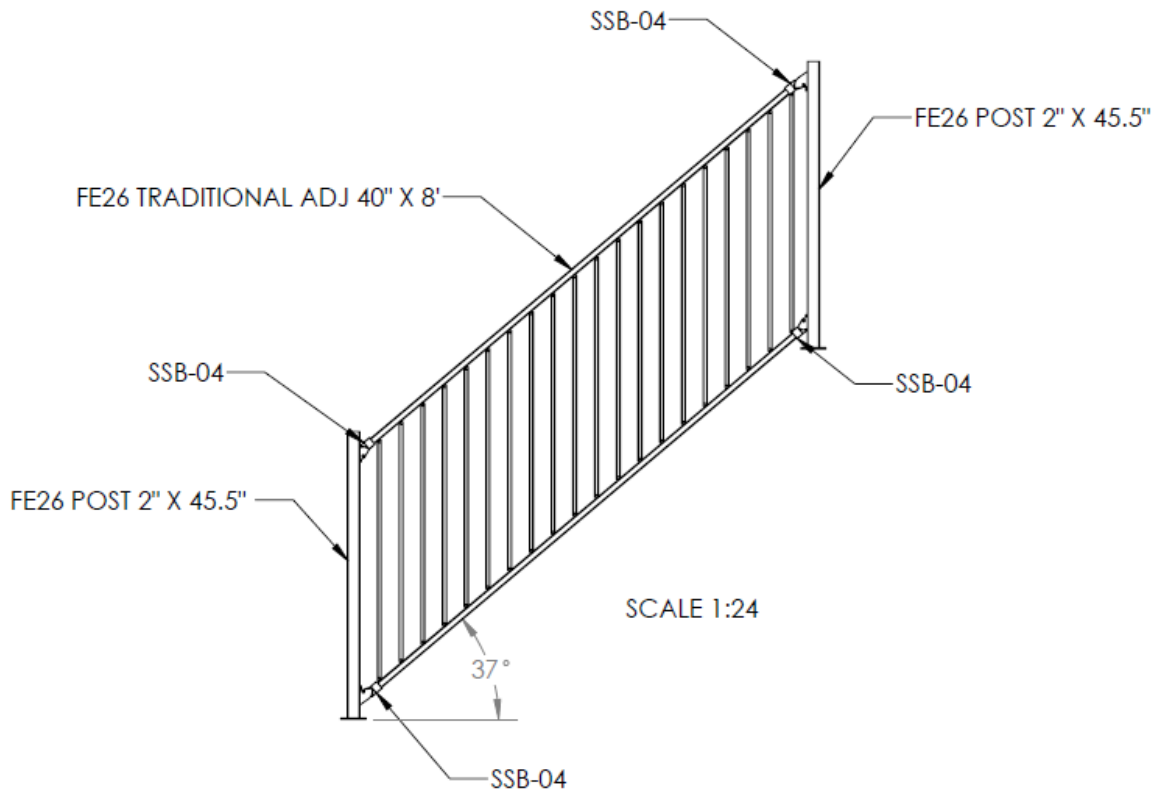

FIGURE 2 – Fe²⁶ TRADITIONAL STAIR RAILING ASSEMBLY

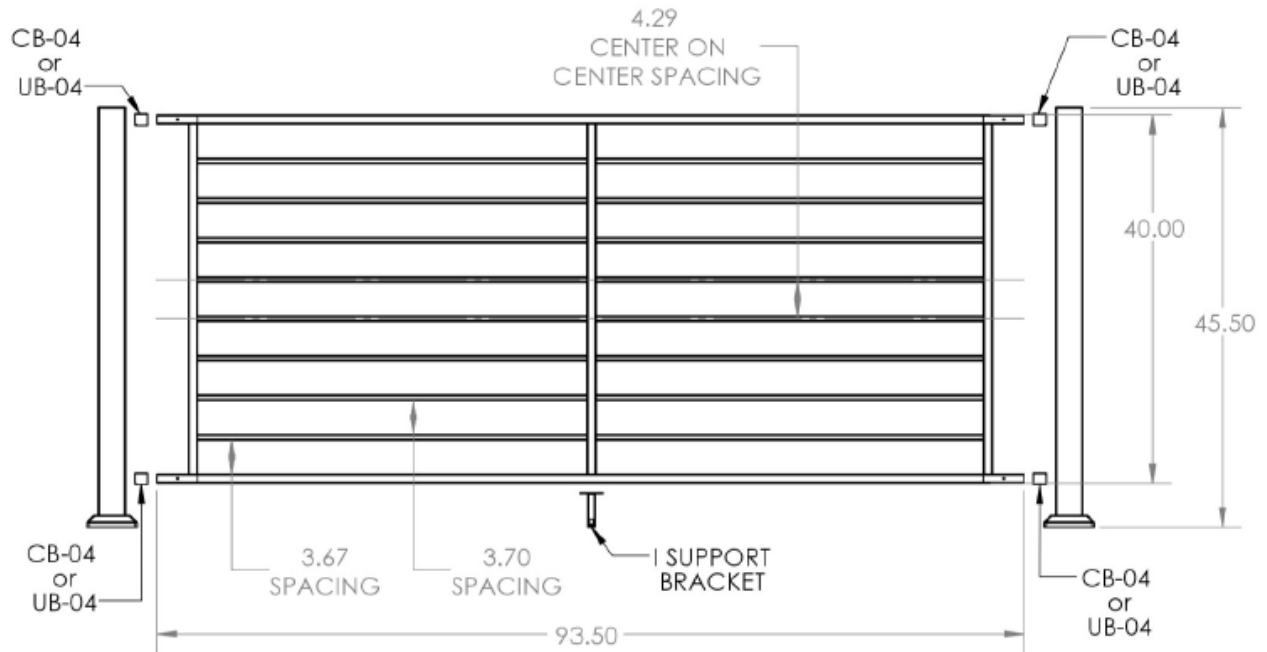

FIGURE 3 – FE²⁶ AXIS LEVEL RAILING ASSEMBLY

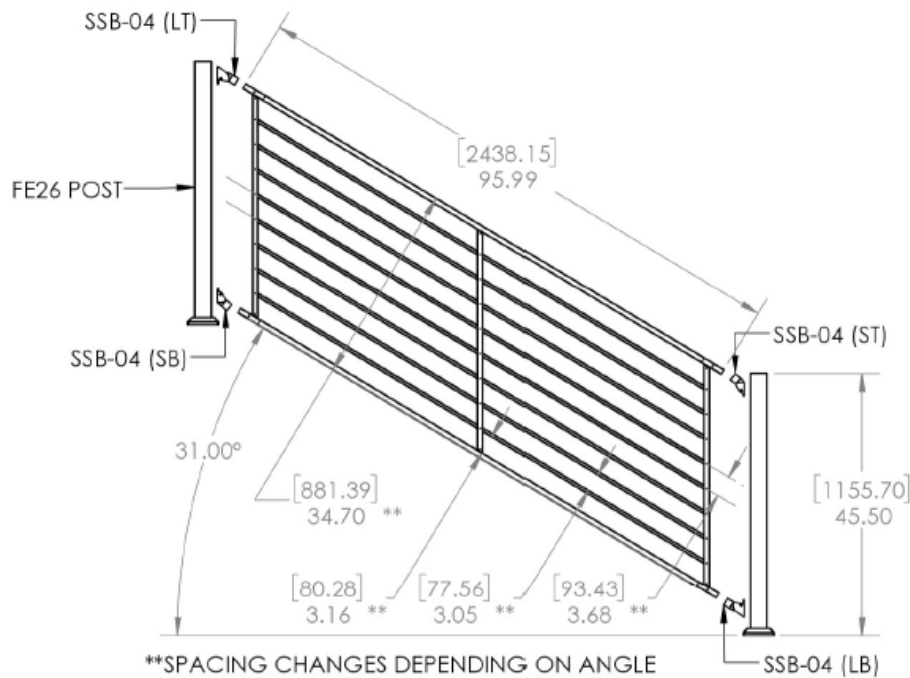

FIGURE 4 – FE²⁶ AXIS STAIR RAILING SYSTEM



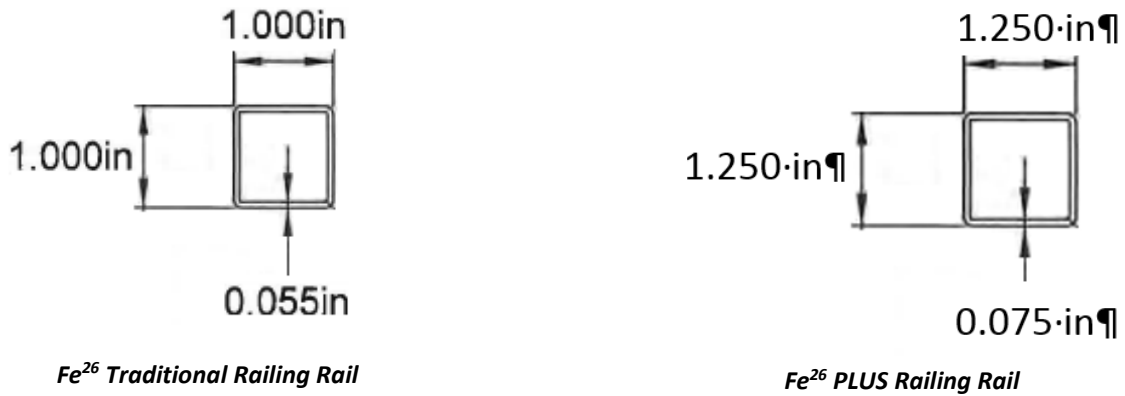

FIGURE 5 – RAILING PROFILES

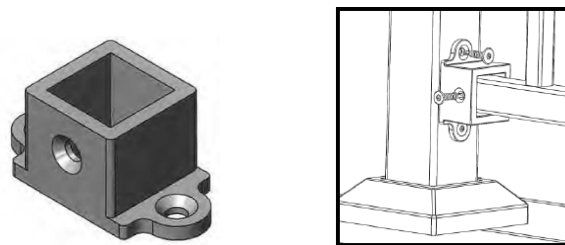

FIGURE 6 – CB-04 COLLAR BRACKET AND INSTALLATION DETAIL FOR THE Fe²⁶ TRADITIONAL RAIL

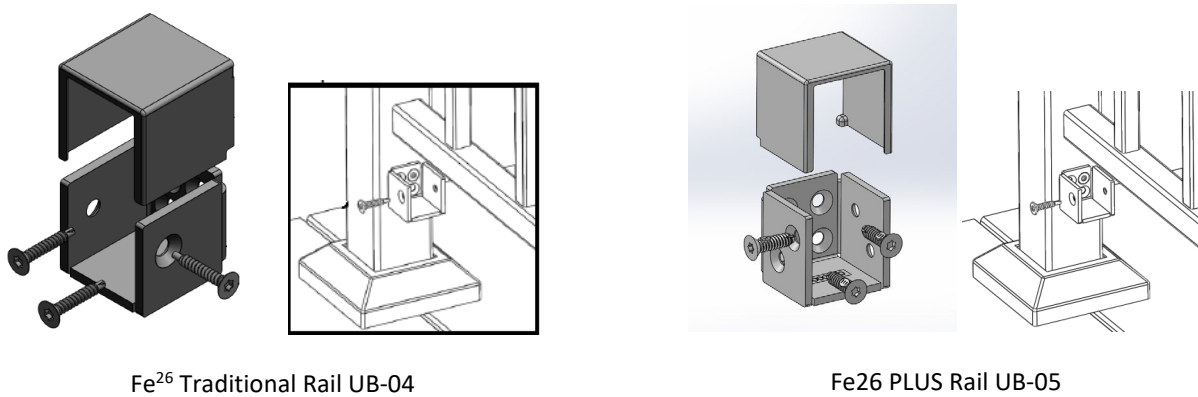

FIGURE 7 – UNIVERSAL BRACKETS AND INSTALLATION DETAIL

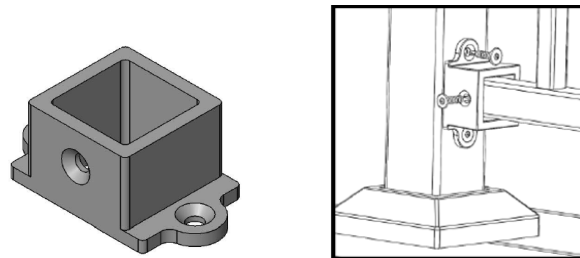

FIGURE 8 – CB-05 COLLAR BRACKET AND INSTALLATION DETAIL FOR THE Fe²⁶ PLUS RAIL

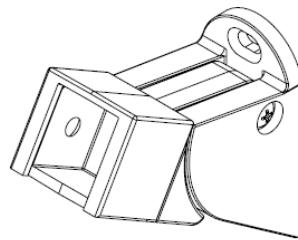
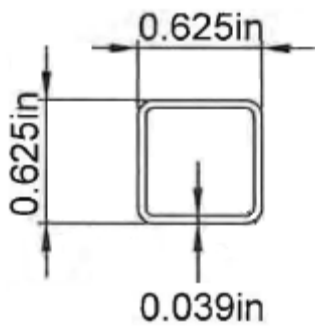
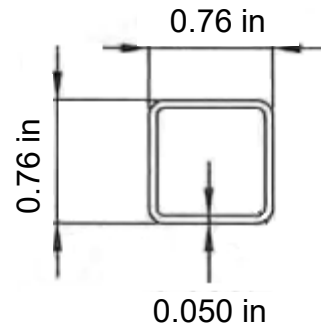

FIGURE 9 – SSB-04 SIMPLIFIED STAIR BRACKET FOR Fe²⁶ TRADITIONAL RAIL AND Fe²⁶ AXIS RAIL FOR ANGLES BETWEEN 29° AND 40°



Fe²⁶ Traditional Railing Baluster
Fe²⁶ Axis Railing Baluster



Fe²⁶ PLUS Railing Baluster

FIGURE 10 – BALUSTER PROFILES

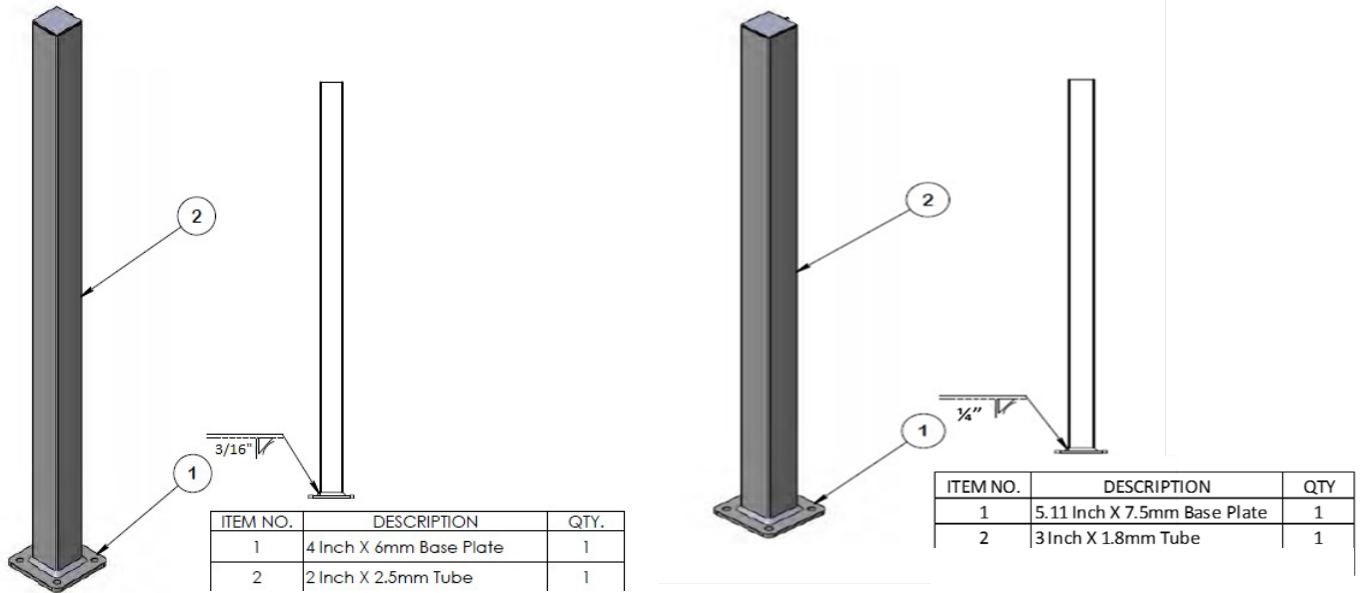

FIGURE 11 – STEEL POST MOUNTS AND BASES

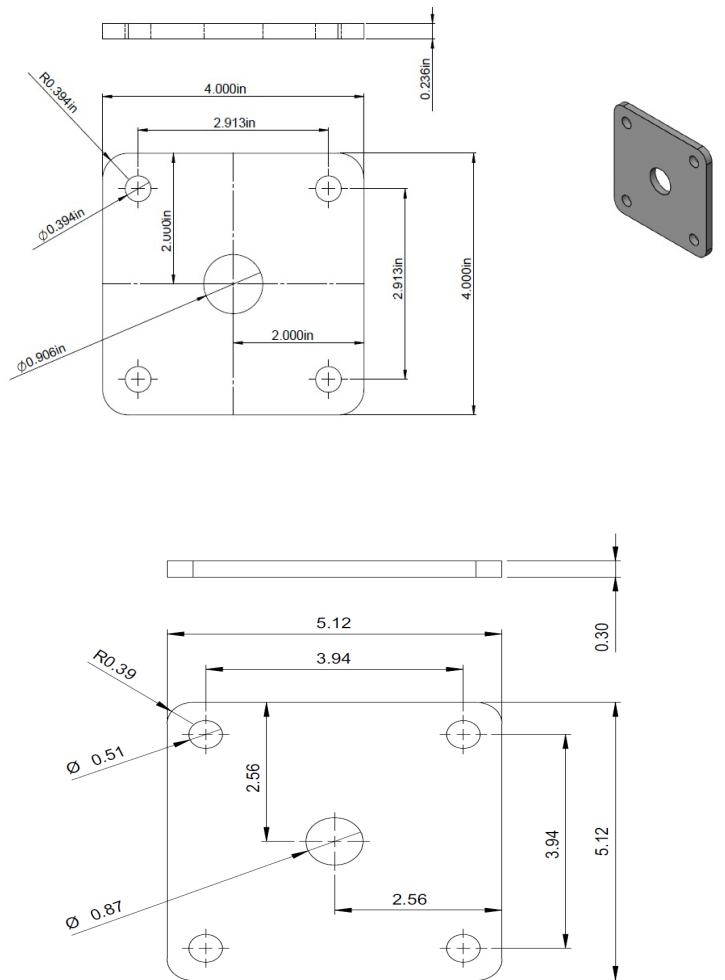

FIGURE 12 – FE²⁶ 2" AND 3" POST BASE PLATES