

TABLE OF CONTENTS

English

Introduction.....	3
Universal Bracket (UB).....	4
Collar Bracket (CB).....	20
Angled Bracket (UB & CB).....	23
Stair Bracket (SSB)	31
Care & Maintenance/Warranty.....	40

INTRODUCTION

READ INSTRUCTIONS COMPLETELY BEFORE STARTING INSTALLATION

It is the responsibility of the installer to meet all code and safety requirements, and to obtain all required building permits. The deck and railing installer should determine and implement appropriate installation techniques for each installation situation. Fortress Railing Products and its distributors shall not be held liable for improper or unsafe installations.

Fortress Posts must always be secured to the deck framing and should never be attached to only the deck boards.

Note

When cutting Fortress railing, it is very important to complete the following at cut points:

- Remove all metal shavings from the cut area.
- File any sharp edges left by cutting. Thoroughly wipe and remove any filings, grime, or dirt from the railing.
- Apply two coats of Fortress zinc based touch-up paint to the cut area. If touch up is at rail ends, allow paint to dry before connecting bracket to post.
- Be sure to remove any metal shavings from the surface of deck, patio, or balcony to prevent stains on the deck surface.

Torx Safety Tips

- Always use the lowest speed setting on drill.
- To reduce chance of bit breakage, start tightening with drill on low torque setting and work up until screw is secured.

Tip: Pre-drill holes with 3/16" [5mm] drill bit.

Required Tools



Goggles



Safety
Gloves



Tape
Measurer



Speed
Square



Level
Tool



Touch-Up
Paint



T-25
Driver Bit



#2 Phillips
Head Bit



Drill Bits: 1/16", 3/16",
3/8", [2mm, 5mm, 10mm]



Bit
Extender



Spring
Punch



Drill



Clamp



Metal Cutting Miter Saw
or Portable Band saw



Hand
Grinder



Rubber
Mallet



Pencil



Wood 2" x 4"



File

UNIVERSAL BRACKET

Fe²⁶ Axis: Universal (UB) Bracket Installation

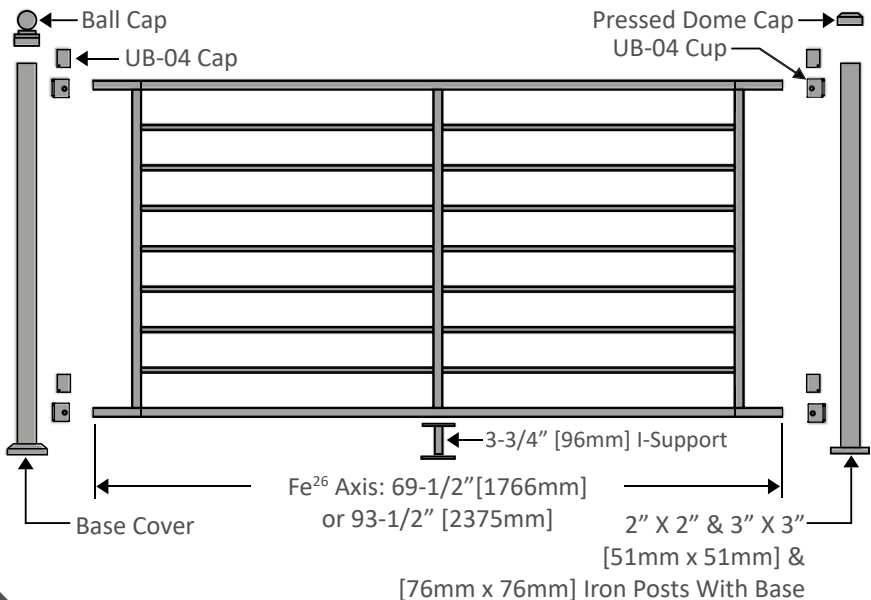

Universal Bracket (UB-04) Post Configuration

Fe²⁶ Axis Height

34" [864mm]

40" [1016mm]

Rail Panel

Installed Panel Height*

37-3/4" [956mm]

43-3/4" [1111mm]

Required Post

39-1/2" [1003mm]

45-1/2" [1156mm]

*Installed heights include a 3-3/4" [96mm] space between deck surface and bottom edge of bottom rail.

UNIVERSAL BRACKET: POST MOUNTING

*If using Fortress Evolution Framing, contact Fortress for instructions.

Note:

It's recommended to install brackets into post before Post Mounting. Reference page 7 for Bracket Installation steps.

Step 1: Install Wood Blocks

1. Install Wood Block level with top of joist. As shown in Fig. 1 below.
2. Secure Wood Block to blocking on all four sides with #10 X 3-1/2" [89mm] deck screws.
 - Wood Block must be constructed with treated dimensional lumber with a minimum thickness of 1-1/2" [38mm].

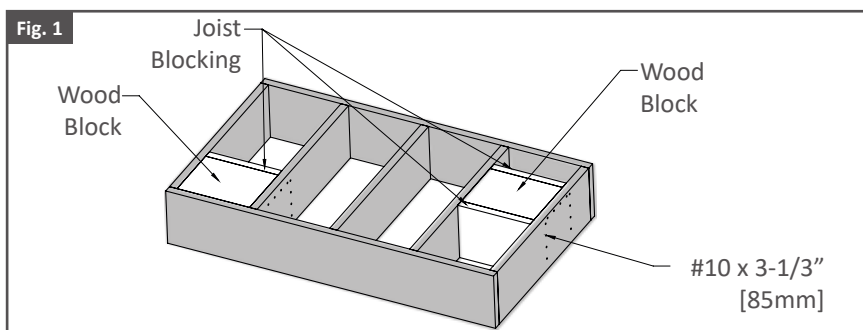

Step 2: Position Base Plate

1. Position the edge of the base plate a minimum of $1/2''$ [13mm] from the inside edge of rim joist. As shown in Fig. 1.

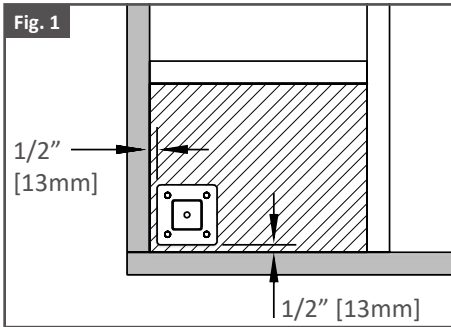

Step 3: Max Post Spacing

- 6' panel maximum post spacing is $69-3/4''$ [1772mm].
- 8' panel maximum post spacing is $93-3/4''$ [2381mm].

Note:

- Using the maximum post spacing will help minimize the amount of required panel cuts.
- **DO NOT** exceed the maximum post spacing.

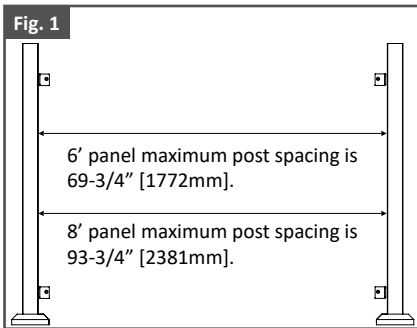

Step 4: Mount Posts

1. Mark mounting hole locations and pre-drill a $3/8''$ [10mm] hole.
2. Insert $3/8'' \times 3-1/2''$ [10mm x 89mm] Hex Head galvanized bolts through $3/8''$ [10mm] galvanized washer and post base plate.

Note:

- Post Base Plate holes **MUST** be positioned a minimum 1/2" [13mm] from edge of deck board.
- Use only 3/8" [10mm] Hex Head Galvanized Bolts. Lag Screws should **NOT** be used. Secure each post with four bolts.

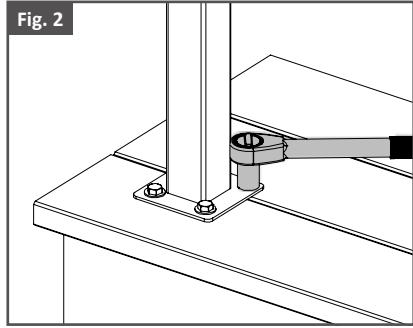
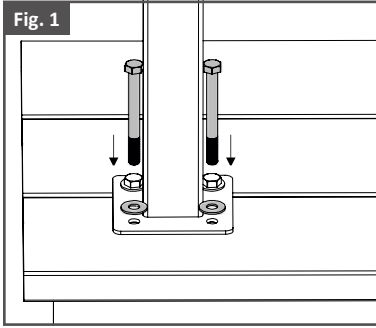

Step 5: Check Mounted Posts

1. Shim post as needed to ensure post is level.

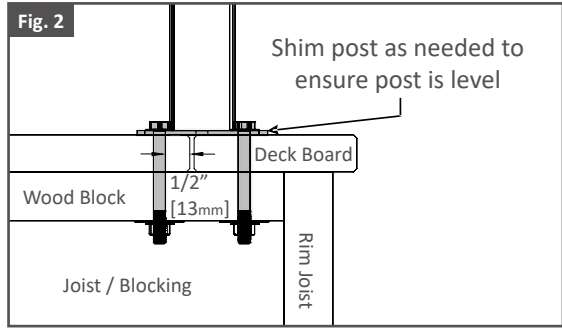
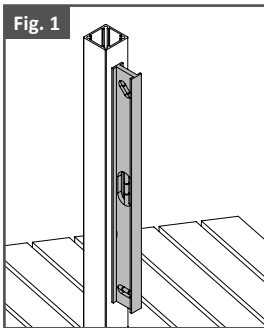

UNIVERSAL BRACKET: BRACKET INSTALLATION

*Fe26 Posts are also available with pre-attached UB-04 brackets.

Step 1: Mark Bracket Hole Locations

1. Mark the centerline of each post with a pencil.
2. Take measurements used in Fig. 1 and 2 to mark bottom and top bracket hole locations onto posts.

Tip:

- Remove all metal shavings before bracket is screwed to post to prevent rust stains.

Fig. 1**UB-04 Bracket Hole Locations**

Pre-drill Dimensions: Pre-drilling with a 3/16" [5mm] drill bit is required

A*	B	C	D
34" [864mm] Panel			
4" [102mm]	1/2" [13mm]	37" [940mm]	1/2" [13mm]
40" [1016mm] Panel			
4" [102mm]	1/2" [13mm]	43" [1092mm]	1/2" [13mm]

*Dimension A positions bottom edge of rail 3-3/4" [96mm] above deck surface.

*Dimension A is measured from the bottom surface of post base.

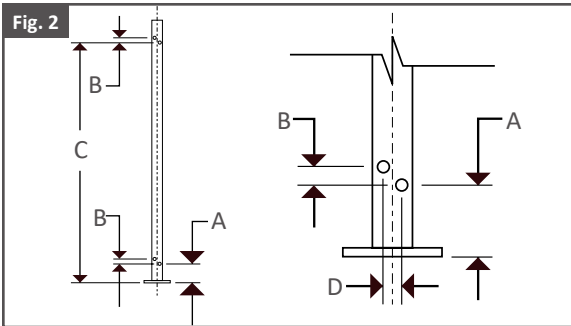
Fig. 2**Step 2: Pre-Drill and Install Brackets****Tip:**

- **It's important to double check dimensions to confirm accuracy of bracket hole locations before drilling.**
1. Use Spring Punch to mark the holes. As shown in Fig. 1.
 2. Pre-drill bracket holes with a 3/16" [5mm] drill bit. As shown in Fig. 2.
 3. Attach Brackets to the posts with supplied T-25 thread-cutting screws. Use two screws per bracket. Use low speed setting on drill. As shown in Fig. 3.
 4. Once top and bottom brackets are installed, remeasure bracket spacing to confirm dimensions used in Fig. 2 and 3 of step 1. As shown in Fig. 4.
 5. Remove all metal shavings from deck, post base cover, post, and panel before bracket is screwed to post to prevent corrosion.

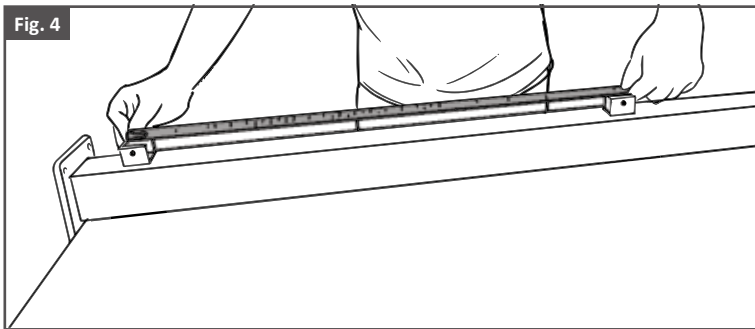
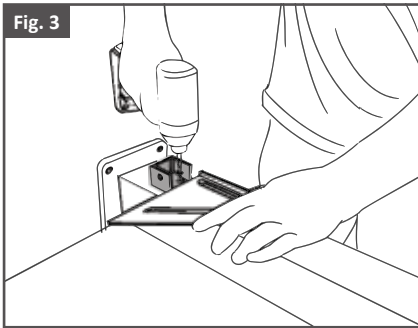
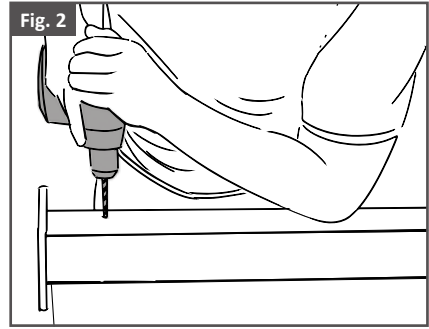
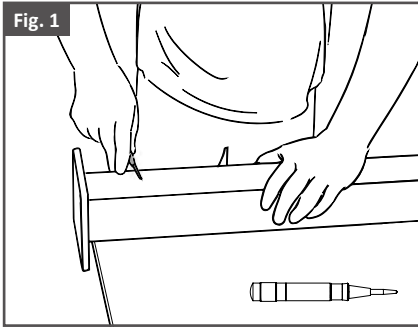

UNIVERSAL BRACKET: CUTTING DOWN PANELS

Step 1: Measure The Panel Opening Length

1. Measure the distance of the panel opening. As shown in Fig. 1.
2. Confirm that the measurements for the top brackets are the same as the bottom brackets.

Note:

- Measure from the back wall of the bracket to the back wall of the bracket on other post. As shown in Fig. 2.

- T-25 Thread Cutting Screws are packaged in a plastic bag and secured to the panel. **DO NOT** discard screws.

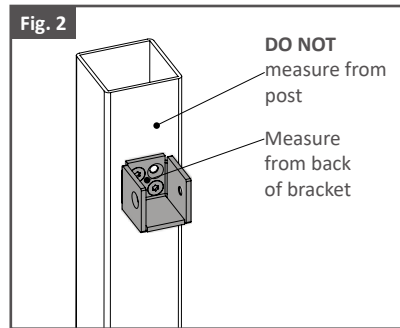
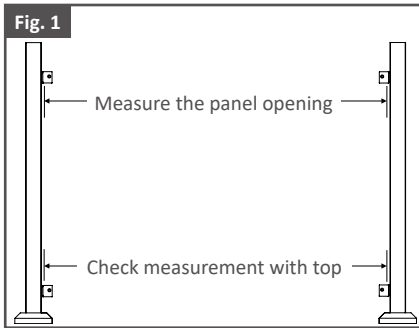

Step 2: Mark Rail & Picket Cut Points

1. Position the panel on a flat surface, preferably a table.
2. To ensure rails are symmetrical, take the measurement found in step 1 and divide it in half.
3. Find and mark the center of the rail.
4. From the previously marked center, measure out the divided length in each direction. As shown in Fig. 1.
5. Mark these locations with a pencil on the top/bottom rail.
6. Using a rubber mallet, remove one of the uprights from the panel. As shown in Fig. 2. **DO NOT** Remove the opposite upright.
7. Place the removed upright on top of loose rails and pickets. Position the back edge of upright in line with the previous marked point and flush with the rails. As shown in Fig. 3.
8. Mark rail cut points on the inside edge of upright. As shown in Fig. 4.
9. Mark picket reference points on outside face of upright. As shown in Fig. 5.
10. On previously marked **PICKET** reference points, remove 1/4" [6mm] and mark the picket cut points. As shown in Fig. 6.
11. Using a speed square, straighten cut point markings on and side faces of rails and pickets. As shown in Fig. 7.

Tip:

- Be sure to have upright positioned correctly when marking cut points.

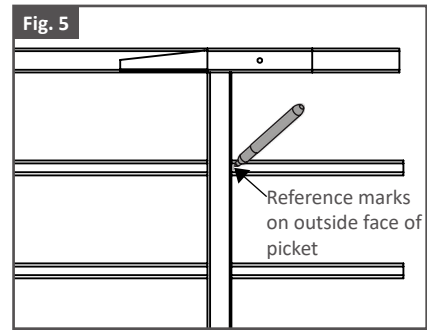
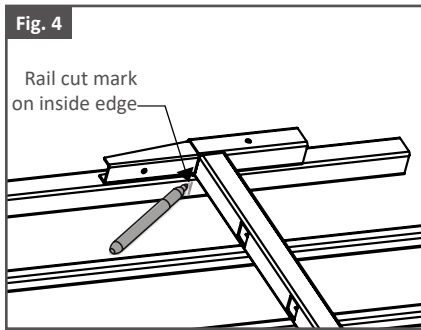
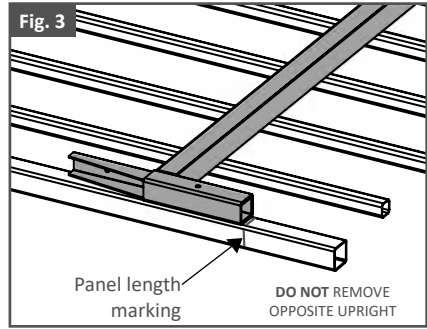
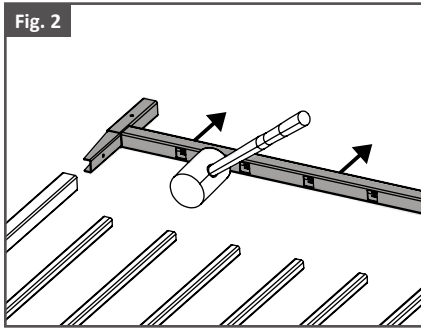
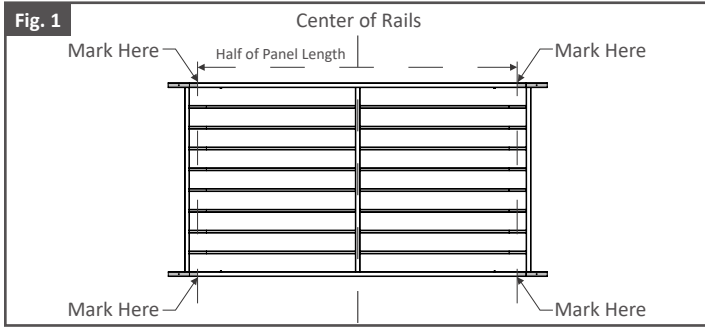

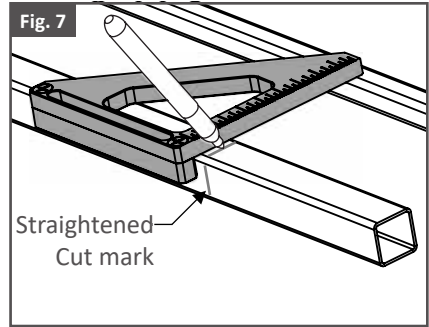
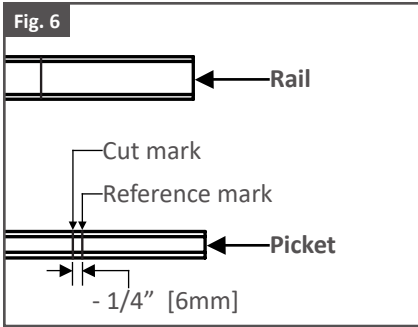

Step 3: Cut Rails & Pickets

1. Cut top and bottom rails using a Portable Band Saw, Circular Saw or Grinder with a cutoff disc. Be sure to follow cut marks on top and side faces. As shown in Fig. 1.
2. Use a circular saw or hand grinder to cut pickets.

Tip:

- Be sure to support rails and pickets when making cuts.
- When cutting pickets, clamp a straight wood 2" x 4" [60mm x 102mm] to create a straight edge for the circular saw to follow. As shown in Fig. 2.
- Always having the opposite upright installed makes it easier to cut while keeping the rails and pickets in place.
- Be sure to follow cut marks on top and side faces.
- Be sure to not over heat the rails and picket when making cuts with a grinder.
- **Before installing upright, empty cutting debris from pickets and rails.**

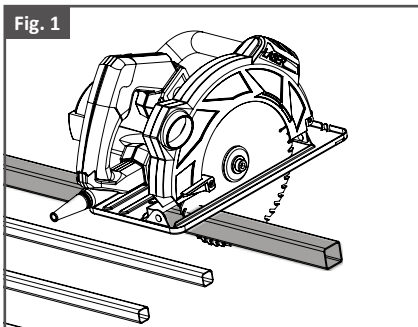

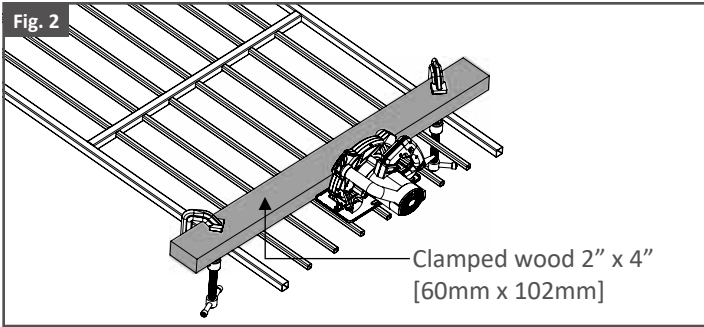

Step 4: Clean Rails & Pickets

1. Use a file to smooth cut edges. As shown in Fig. 1.
2. Remove any metal shavings and dust with a brush or rag.
3. Make sure surfaces to be painted are clean.

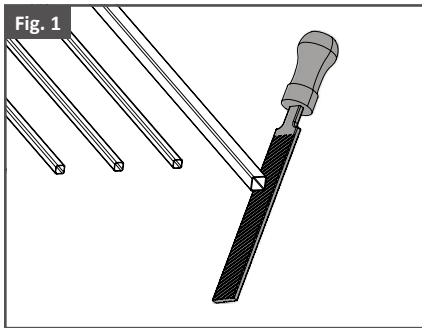

Step 5: Apply Spray Paint To Cut Areas

1. Using a piece of cardboard as a mask, apply the 1st coat of Fortress zinc based touch-up paint.
2. Allow to dry before applying second coat.
3. Apply the 2nd coat of Fortress zinc based touch-up paint.
4. Allow to dry and install.

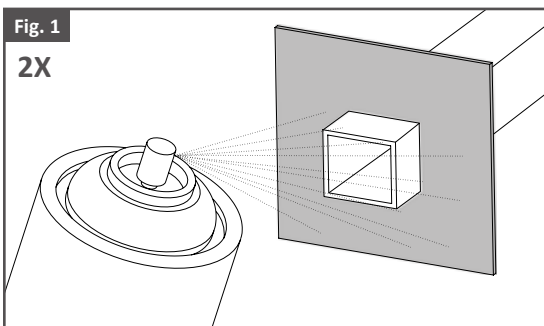

Step 6: Install Uprights

1. Insert uprights into the cut panel. As shown in Fig. 1.
2. Starting on one end, use a rubber mallet to fully seat upright on to rails and pickets. As shown in Fig. 2.

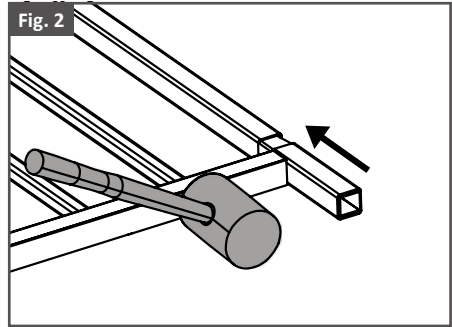
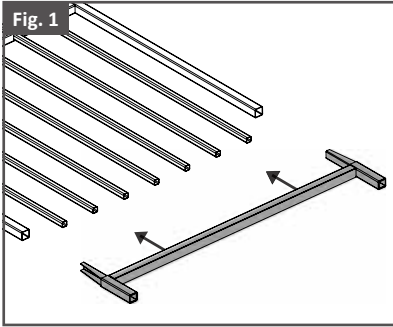

Step 7: Cut Opposite Side Of Panel

1. Repeat steps 1 - 6 for the opposite side of panel.

Step 8: Test Fit Panel

1. Once both uprights are inserted, test fit the panel to confirm length. As shown in Fig. 1.
2. Confirm inside face of post to inside face upright spacing. **CANNOT** exceed 4" [102mm].

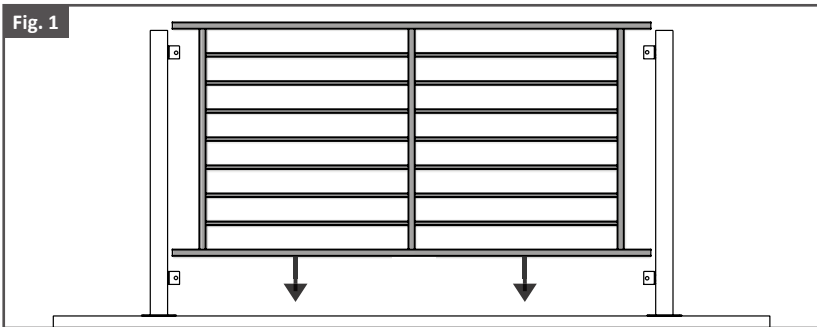

Step 9: Install Set Screws

1. Once panel length is confirmed, measure 1/2" from inside edge of upright and mark screw hole. As shown in Fig. 1.
2. Pre-drill screw holes with a 3/16" [5mm] drill bit.
3. Attach screw to the panel and upright with supplied T-25 Pan Head Self Taping Screws. Use low speed setting on drill. As shown in Fig. 2.

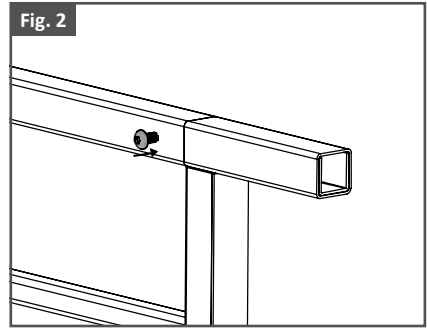
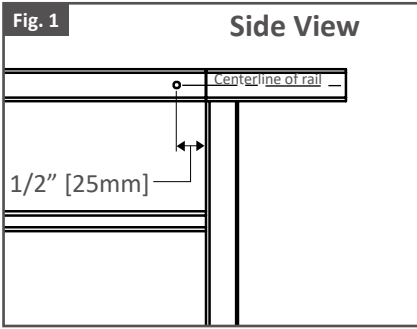

UNIVERSAL BRACKET: PANEL INSTALLATION

Step 1: Determine The Top & Bottom Of Panel

1. Use the Manufacturing Date Code (MDC) Stamp to determine the bottom of the panel. The MDC Stamp can be found on the bottom inside face of the middle upright. As shown in Fig. 1.

Tip:

- The bottom of the panel can also be determined by the spot welds. Spot welds on the panel should face down and be on the under side of the rails. As shown in Fig. 2.

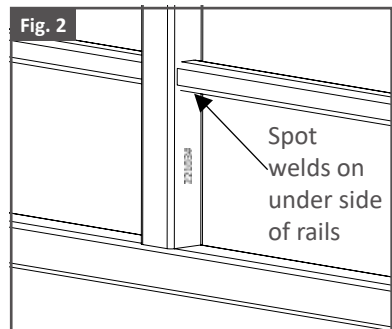
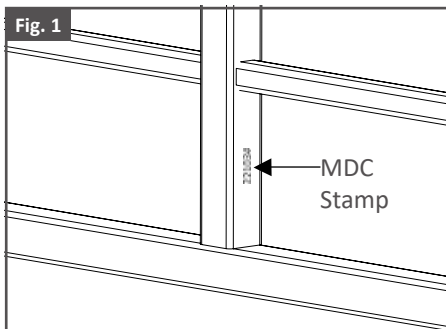

Step 2: Install I-Support On Bottom Rail (Optional)

1. Measure and locate the center of the bottom rail. Using the I-Support as a guide, mark the center of the 2 screw holes. As shown in Fig. 1.
2. Using a 3/16" [5mm] drill bit, drill through the outside wall.
3. Install the I-Support with the provided T-25 thread cutting screws. As shown in Fig. 2.

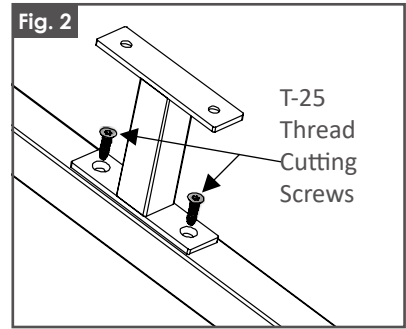
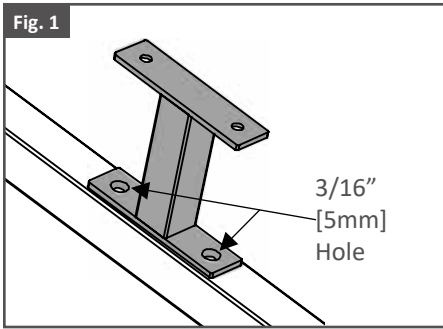

Step 3: Install Panel

1. Install cut panel to ensure proper fit. As shown in Fig. 1.

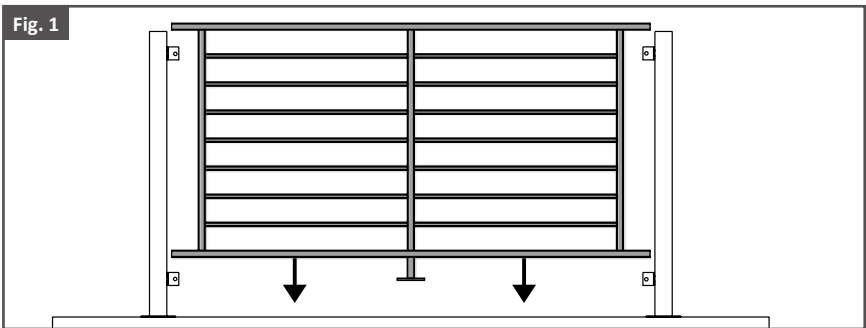

Step 4: Attach Panel To Bottom & Top Brackets

1. Pre-drill holes for screws using a 3/16" [5mm] drill bit.
2. Install screws into bottom & top brackets. As shown in Fig. 1.

Note:

- Only one screw per bracket is needed to secure the bracket to the panel.
- Screws should be installed on the same side of brackets.

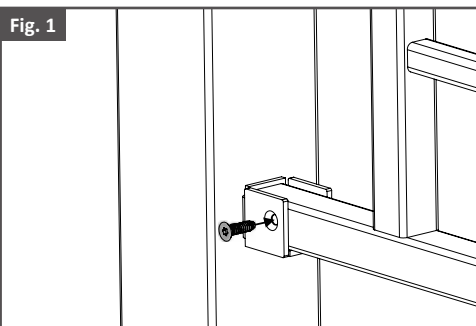

Step 5: Attach I-support To Deck (Optional)

1. Fasten I-support to deck surface with the supported T-25 Wood screws. As shown in Fig. 1.

Tip:

- Pre-drill with a 1/16" [2mm] drill bit.

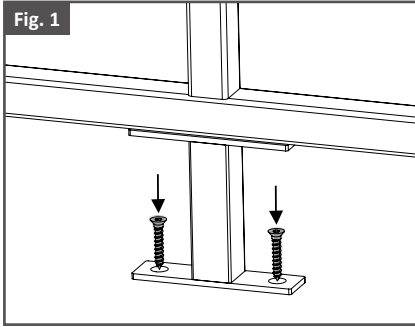

UNIVERSAL BRACKET: POST BASE COVER, BRACKET CAP & PRESSED DOME/BALL CAP INSTALLATION

Step 1: Install Post Base Cover

1. Separate the two-piece base plate cover. Hold one side parallel to the post base plate. As shown in Fig. 1.
2. Place 2nd half of the post base cover on the opposite side of the post. Hold 2nd piece slightly under the 1st piece. As shown in Fig. 2.
3. Twist the 2nd cover ¼ turn and move piece until both half's touch. As shown in Fig. 3.
4. Make sure one of the locking pins on the 2nd cover engage with the proper slot on the 1st cover piece. As shown in Fig. 4.
5. Once the first locking pin is started, turn the 2nd cover piece back parallel to the post base plate. One you have confirmed both locking pins have engaged with the opposing slots lower both half's over the post base plate. As shown in Fig. 5.

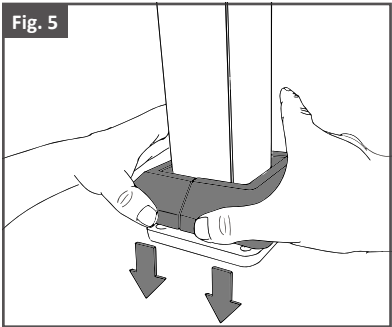
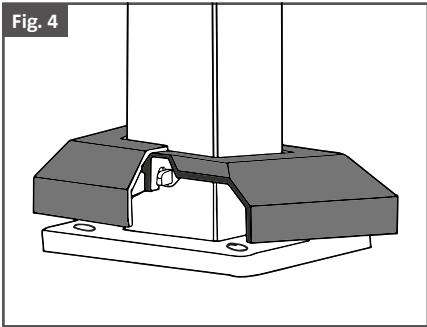
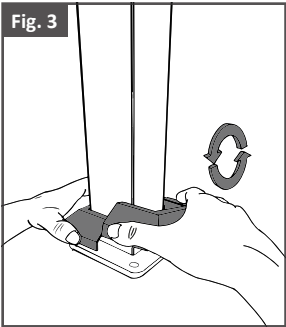
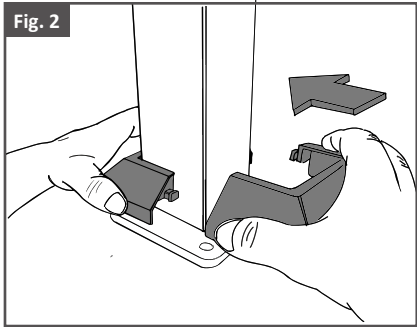
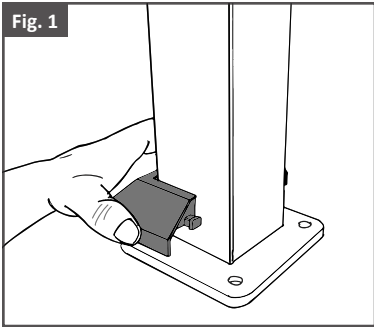

Step 2: Install Bracket Caps

1. Bracket Caps snap over Bracket Caps. As shown in Fig. 1 & 2.

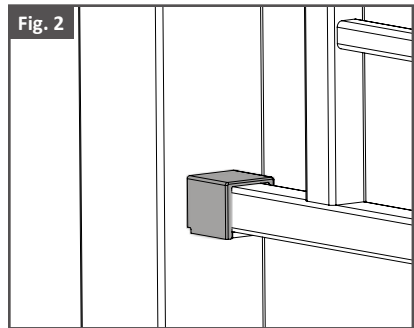
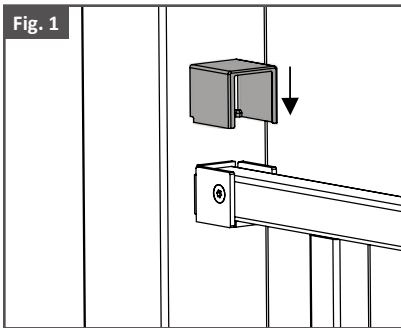

Step 3: Install Pressed Dome Cap

1. Pressed Dome Caps & Ball Caps are press fit into place. As shown in Fig. 1 & 2.

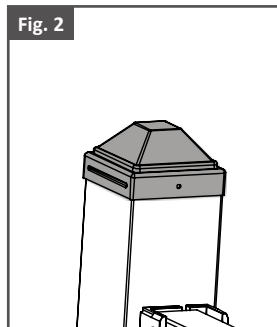
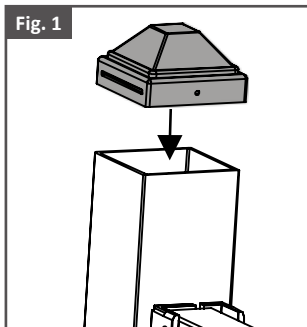

COLLAR BRACKET

Fe²⁶ Axis: Collar Brackets (CB-04) Installation

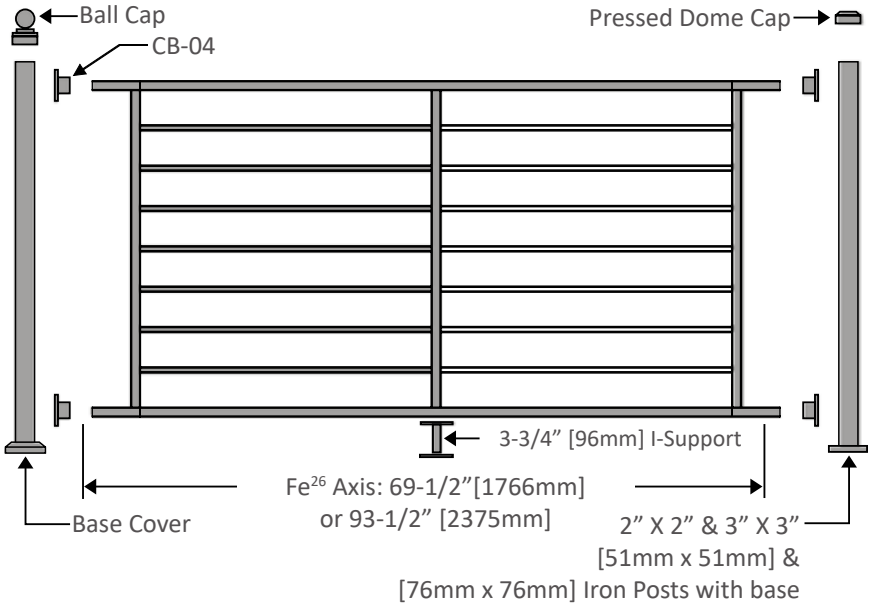

Collar Bracket (CB-04) Post Configuration		
Fe ²⁶ Axis Height	Rail Panel	
	Installed Panel Height*	Required Post
34" [864mm]	37-3/4" [959mm]	39-1/2" [1003mm]
40" [1016mm]	43-3/4" [1111mm]	45-1/2" [1156mm]

*Installed heights include a 3-3/4" [96mm] space between deck surface and bottom edge of bottom rail.

COLLAR BRACKET: POST MOUNTING

- Reference Post Mounting instructions on page 5.

Note:

IT'S RECOMMENDED TO INSTALL BRACKETS ON TO POST BEFORE POST MOUNTING.

COLLAR BRACKET: BRACKET INSTALLATION

Step 1: Mark Bracket Hole Locations

- Reference Bracket hole marking instructions on page 7.

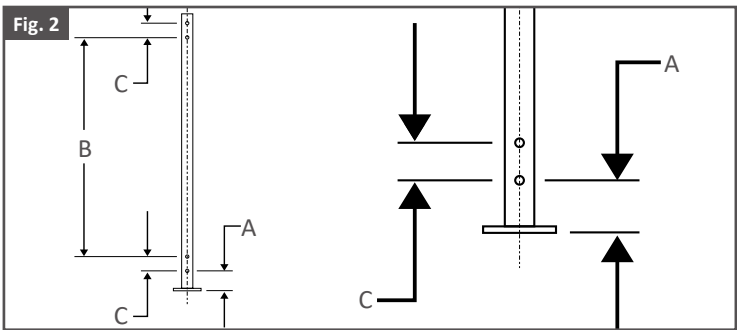
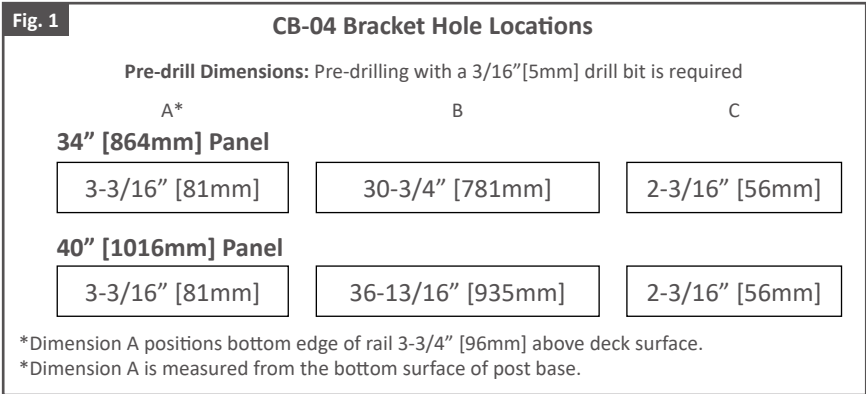

Step 2: Pre-Drill Bracket Holes

- Reference Bracket hole pre-drilling instructions on page 8, step 2.

Note:

- **DO NOT** install Brackets in this step.

COLLAR BRACKET: CUTTING DOWN PANELS

- Reference pages 9 - 15 for panel cutting steps.

COLLAR BRACKET: PANEL INSTALLATION

Step 1: Install I-Support On Bottom Rail

- Reference I-support installation step on pages 15 & 16.

Step 2: Install Panel

1. Slide CB-04 Brackets over each end of the bottom and top rails. Make sure that all set screw holes face the desired direction. As shown in Fig. 1.
2. Secure Brackets into pre-drilled Bracket holes on post with provided T-25 Drive Thread-Cutting Screws.
3. Pre-drill Bracket Set Screw holes on bottom Rail using a 3/16" [5mm] drill bit.
4. Secure Bracket to Rail with provided T-25 Drive Thread-Cutting Screws. As shown in Fig. 2. Use low speed setting on drill.

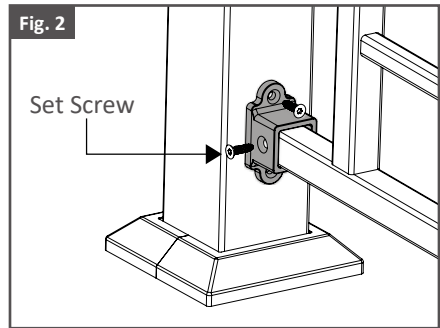
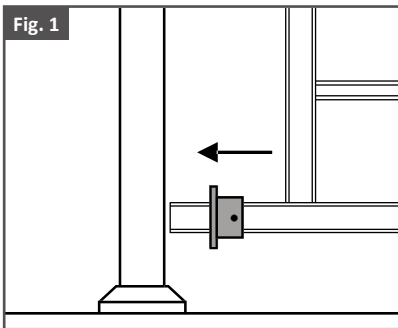

Step 3: Attach I-Support To Deck

- Reference I-support mounting step on page 17.

COLLAR BRACKET: POST BASE COVER, BRACKET CAP & PRESSED DOME/BALL CAP INSTALLATION

- Reference Post Base Cover, Bracket Cap & Pressed Dome/ Ball Cap instructions on pages 17 - 19.

ANGLE BRACKET

Fe²⁶ Axis: Angled Bracket Installation Options

Universal Bracket (UB-04) With Angle Adapter

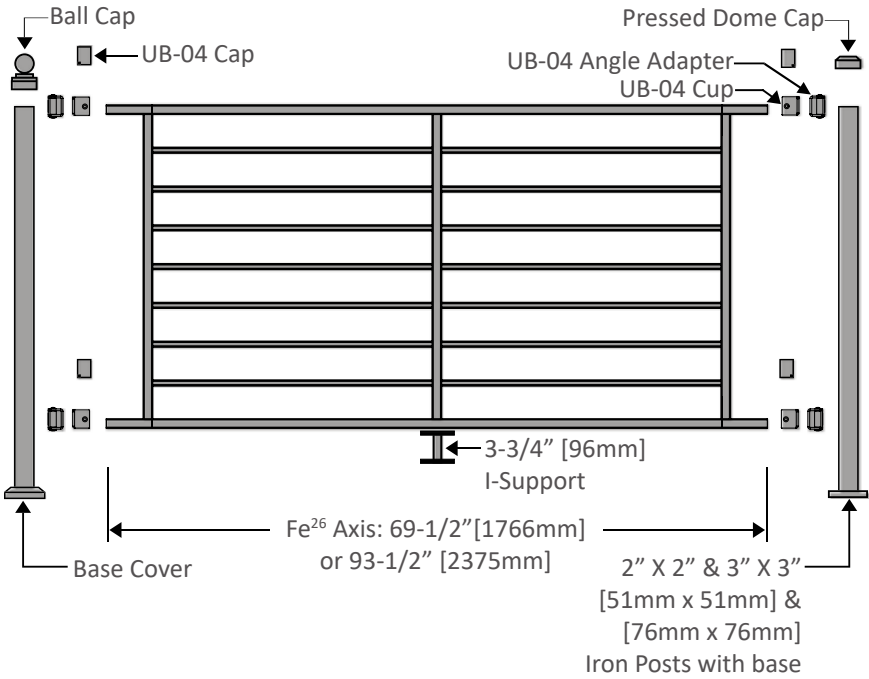

Universal Bracket (UB-04) with Angle Adapter Post Configuration

Fe ²⁶ Axis Height	Rail Panel	
	Installed Panel Height*	Required Post
34" [864mm]	37-3/4" [959mm]	39-1/2" [1003mm]
40" [1016mm]	43-3/4" [1111mm]	45-1/2" [1156mm]

*Installed heights include a 3-3/4" [96mm] space between deck surface and bottom edge of bottom rail.

Universal Bracket (UB-04) with Angle Adapter

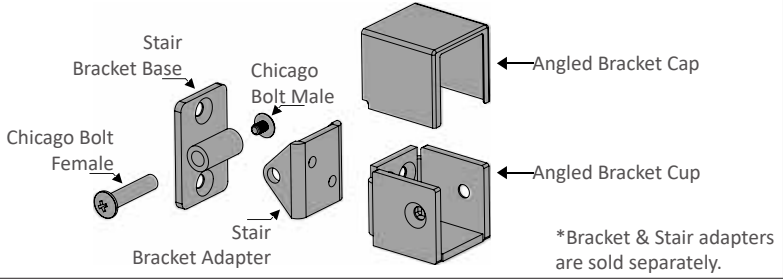

Collar Bracket Side Adjustable (CBS-04)

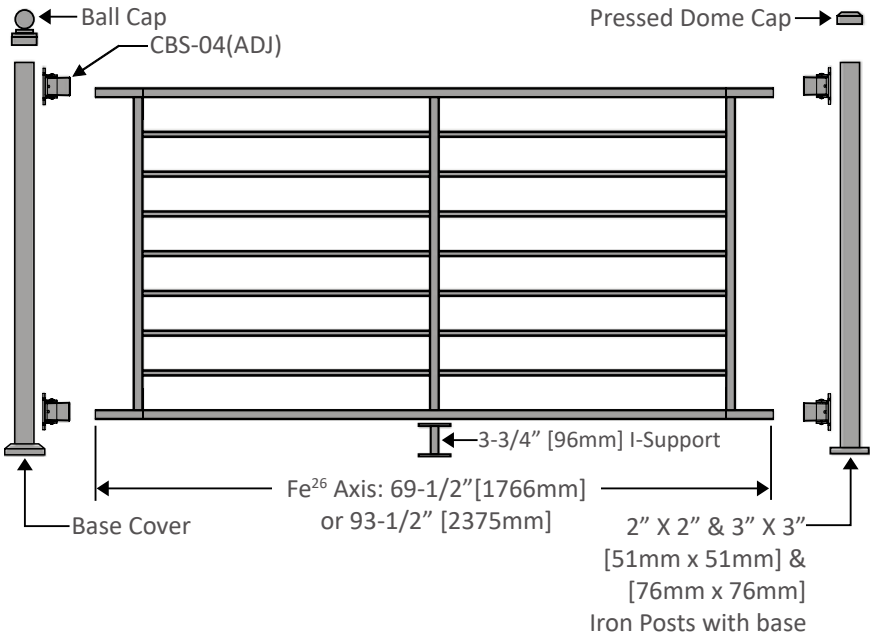

Collar Bracket Side Adjustable (CBS-04) Post Configuration

Fe ²⁶ Axis Height	Rail Panel	
	Installed Panel Height*	Required Post
34" [864mm]	37-3/4" [959mm]	39-1/2" [1003mm]
40" [1016mm]	43-3/4" [1111mm]	45-1/2" [1156mm]

*Installed heights include a 3-3/4" [96mm] space between deck surface and bottom edge of bottom rail.

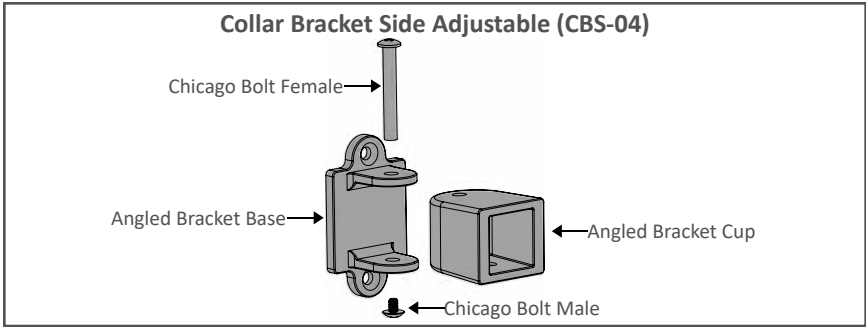

ANGLE BRACKET: POST MOUNTING

- Reference Post Mounting instructions on page 5.

Note:

IT'S RECOMMENDED TO INSTALL BRACKETS ON TO POST BEFORE POST MOUNTING.

ANGLE BRACKET: BRACKET INSTALLATION (UB-04 or CBS-04)

Note:

THE BRACKET INSTALLATION INSTRUCTIONS COVER BOTH UB-04 & CB-04, ONLY USE STEPS SPECIFIC TO BRACKET BEING INSTALLED.

Step 1: Mark Bracket Hole Locations (UB-04 or CBS-04)

1. Mark the centerline of each post with a pencil.
2. Take measurements used to mark bottom and top bracket hole locations onto posts. Reference Fig. 1 and 2 for UB and Fig. 3 and 4 for CB.

Note:

- Installed panel heights include space between the deck surface and underside of bottom rail. Fe²⁶ has a spacing of 3-3/4" [96mm] spacing.

Fig. 1**UB-04 With Angle Adapter Bracket Hole Locations**

Pre-drill Dimensions: Pre-drilling with a 3/16" [5mm] drill bit is required

A*	B	C
34" [864mm] Panel		
4-3/16" [106mm]	37-3/16" [945mm]	1"-3/16" [30mm]
40" [1016mm] Panel		
4-3/16" [106mm]	43-3/16" 1097mm]	1"-3/16" [30mm]

*Dimension A positions bottom edge of rail 3-3/4" [96mm] above deck surface.

*Dimension A is measured from the bottom surface of post base.

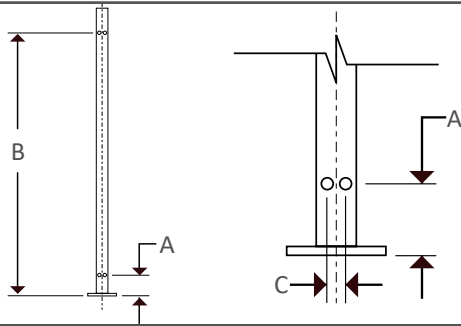
Fig. 2**UB-04 With Angle Adapter****Fig. 3****CBS-04 Bracket Hole Locations**

Pre-drill Dimensions: Pre-drilling with a 3/16" [5mm] drill bit is required

A*	B	C
34" [864mm] Panel		
4-1/4" [108mm]	37-1/4" [946mm]	2-1/8" [54mm]
40" [1016mm] Panel		
4-1/4" [108mm]	43-1/4" [1099mm]	2-1/8" [54mm]

*Dimension A positions bottom edge of rail 3-3/4" [96mm] above deck surface.

*Dimension A is measured from the bottom surface of post base.

Fig. 4

CBS-04 Bracket

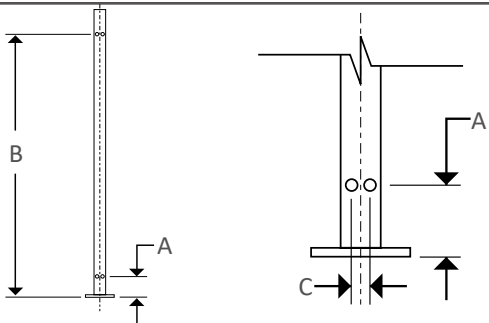

Step 2: Pre-drill Angle Bracket Holes

Tip:

- It's important to double check dimensions to confirm accuracy of bracket hole locations before drilling.
1. Use Spring Punch to mark the holes. As shown in Fig. 1.
 2. Pre-drill bracket holes with a 3/16" [5mm] drill bit. As shown in Fig. 2 & 3.
 3. Remove the bolt from the Angle Bracket Assembly.

Fig. 1

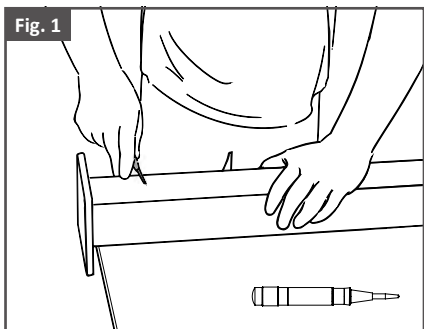

Fig. 2

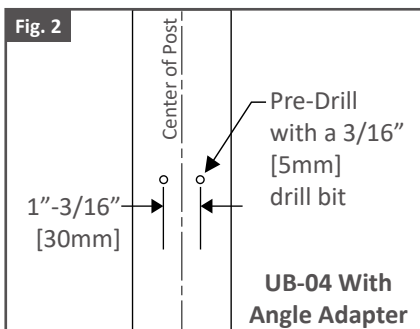
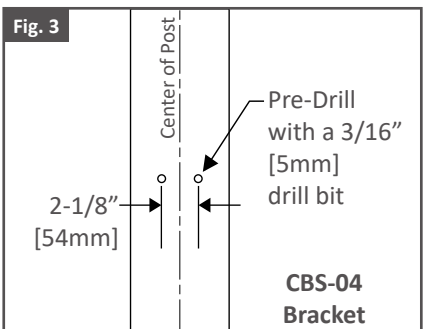

Fig. 3



Step 3: Install UB-04 With Angle Adapter

1. Attach Angle Adapter Base piece to the posts with supplied T-25 Thread-Cutting Screws. Use low speed setting on drill. As shown in Fig. 1.
2. Assemble Angle Adapter Body piece & Base piece. As shown in Fig. 2.
3. Attach UB-04 Bracket to Angle Adapter using T-25 Thread-Cutting Screws. As shown in Fig. 3.

Tip:

- Use a Bit Extender for an easier screw fastening process.

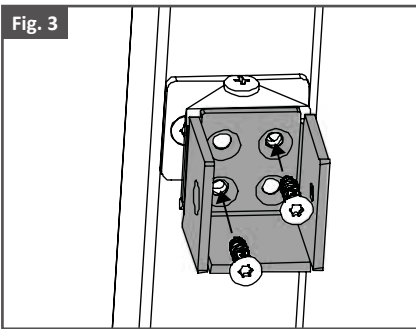
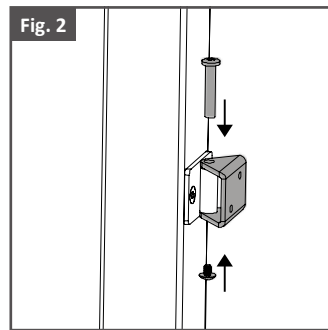
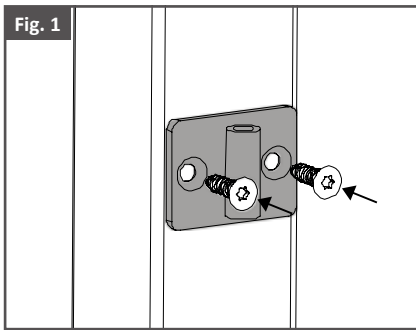

Step 4: Install CBS-04 Bracket

1. Attach Angle Bracket Base piece to the posts with supplied T-25 thread-cutting screws. Use low speed setting on drill. As shown in Fig. 1.
2. Assemble Angle Bracket Body piece & Base piece. As shown in Fig. 2.

Tip:

- Use a Bit Extender for an easier screw fastening process.

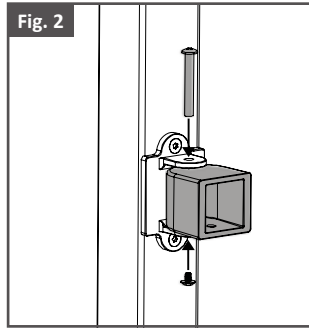
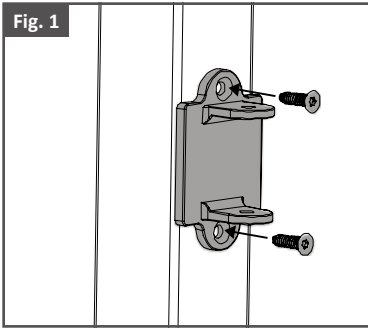

Step 5: Determine Panel Length

1. Check to ensure that all posts are square and straight. Shim posts as required.
2. Ensure that the Angle Bracket Cups are approximately aligned.
3. With another person's help, measure the distance from the inside back of one cup to the inside back of the other cup. This will be the panel length. As shown in Fig. 2 & 3.

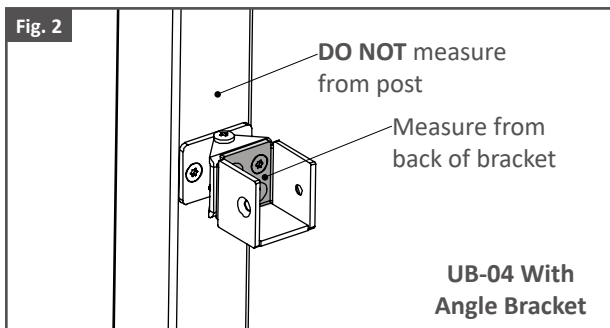
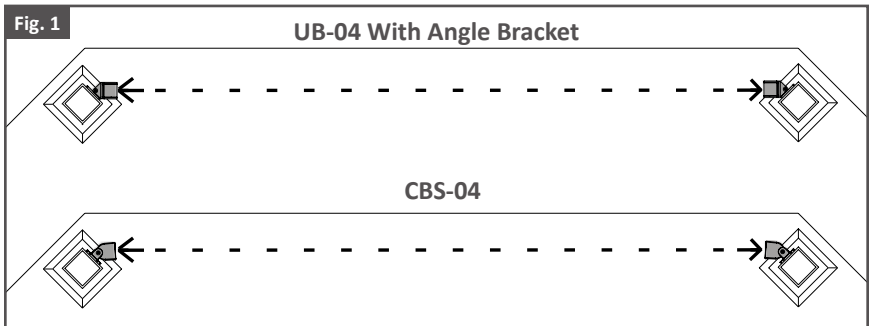
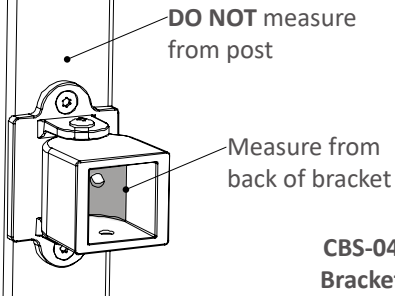

Fig. 3



ANGLE BRACKET: CUTTING DOWN PANELS

- Reference pages 9 - 15 for panel cutting steps.

ANGLE BRACKET: PANEL INSTALLATION

- Reference UB-04 panel installation steps on pages 15 - 17 and CB-04 panel installation steps on page 22.

ANGLE BRACKET: POST BASE COVER, BRACKET CAP & PRESSED DOME/BALL CAP INSTALLATION

- Reference Post Base Cover, Bracket Cap & Pressed Dome/ Ball Cap instructions on pages 17 - 19.

STAIR BRACKET

Fe²⁶ Axis: Stair Bracket Installation

Simplified Stair Bracket (SSB-04)

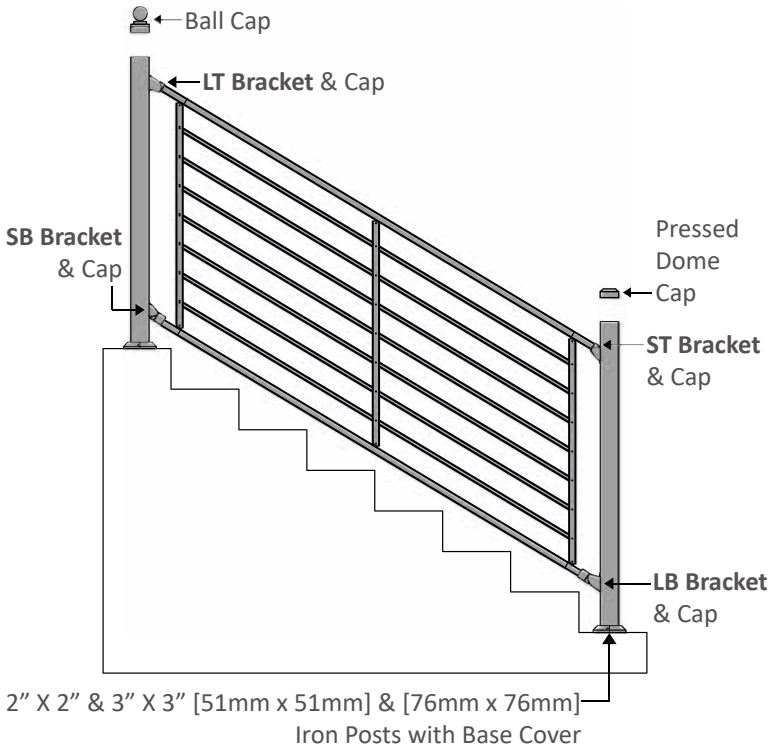

Simplified Stair Bracket

Each bracket base of the SSB's has a stamped letter marking on the outside face to show the bracket being used

Back View

Each bracket cup of the SSB's has a stamped letter marking on the inside face to show the bracket being used

Front View

Bracket Letter Marking:
S: Small L: Large B: Bottom T: Top

- Available Lengths: 6' [1829mm] and 8' [2438mm].
- Available Heights: 34" (864mm) and 40" (1016mm).
- Adjustable Angle Range: 31° to 37°.
- Fe²⁶ Axis stair panels are designed to be installed with SSB brackets **ONLY**.

Simplified Stair Bracket (SSB-04): LT

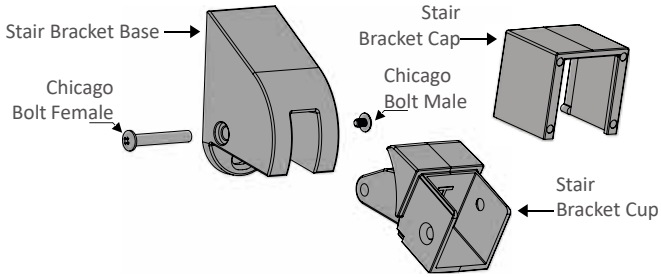

Simplified Stair Bracket (SSB-04): SB

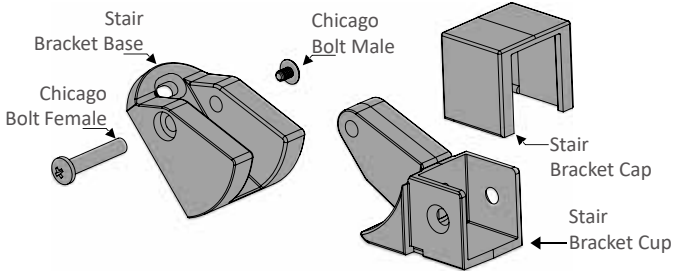

Simplified Stair Bracket (SSB-04): ST

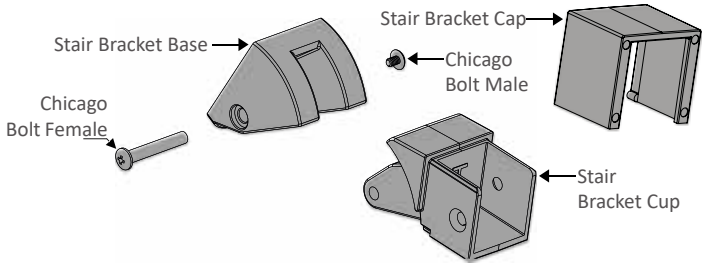

Simplified Stair Bracket (SSB-04): LB

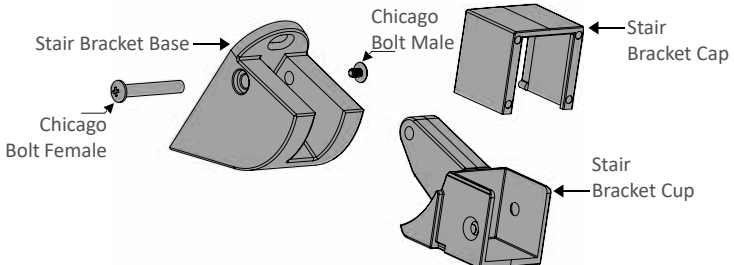

STAIR BRACKET: BRACKET INSTALLATION

Bracket Options

- When installing SSB brackets, Identify the 4 brackets (LT, ST, LB and SB) by the letters stamped in each part.
- Reference the installed panel image at the top of pages 31 & 32 for placement of each SSB bracket.

Step 1: Bottom Bracket Installation

1. Position wood 2" x 4" [60mm x 102mm] between posts. As shown in Fig. 1.
2. Position bottom brackets centered flat on post & wood 2" x 4" [60mm x 102mm]. Use pencil to mark top edge of bracket location on post. As shown in Fig. 2.
3. Disassemble the bracket by removing the barrel and screw. Reference the bracket options on page 32.
4. Place bracket base on previous top edge mark. Center the base on the post and use pencil to add marks for two screw hole locations. As shown in Fig. 3.

Note:

- Be sure bracket base is centered on post when marking hole locations.

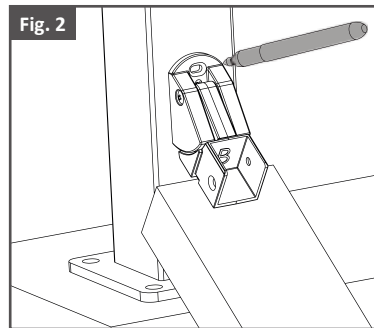
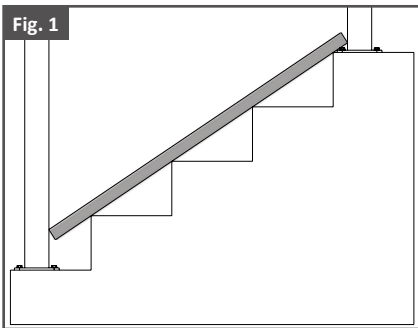

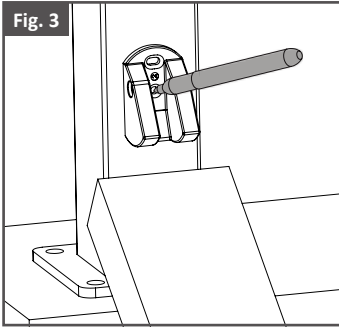

Step 2: Bottom Bracket Installation Continued

1. Use Spring Punch to mark the holes. As shown in Fig. 1.
2. Drill out bracket hole with a 3/16" [5mm] drill bit. As shown in Fig. 2.
3. Use T-25 screws to attach the base to the post. Begin with bottom hole then top. As shown in Fig. 3.
4. Keep bracket base centered as you install second screw.
5. Insert barrel & screw to re-assemble bracket.
6. Tighten barrel & screw. As shown in Fig. 4.

Note:

- Lower Post may need to be unmounted to install bracket then remounted.

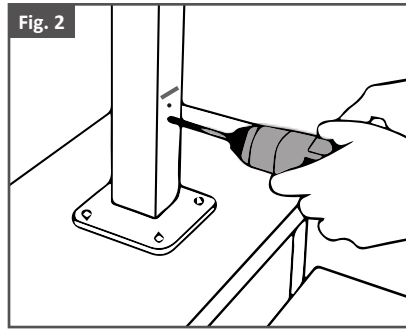
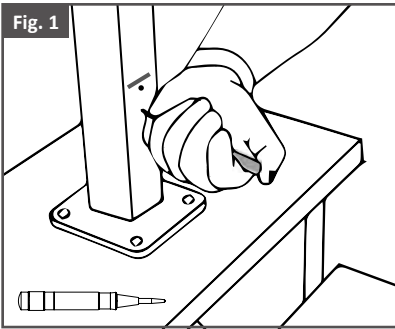

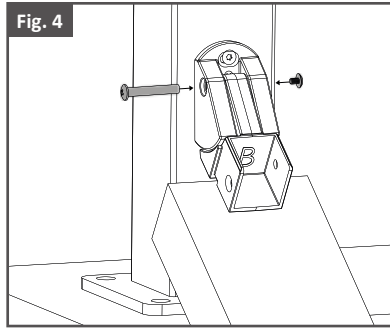
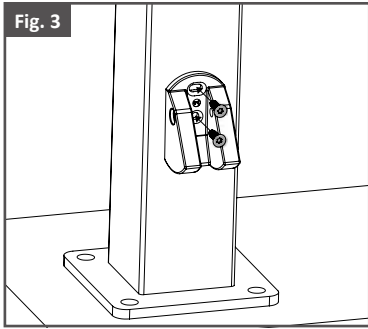

Step 3: Top Bracket Installation

1. Position wood 2" x 4" [60mm x 102mm] on stairs in line with bottom brackets.
2. Place panel on top of wood 2" x 4" [60mm x 102mm] next to bottom brackets. As shown in Fig. 1.
3. Rake the panel until center upright is parallel to the post or level and positioned as close to final installation position as possible.
4. Clamp the panel to the post. Be sure to clamp at four touch points to keep panel in position. As shown in Fig. 2.
5. Position bracket parallel with top rail & flat centered on post. **Make sure inside bottom of bracket is flush with bottom of rail. As shown in Fig. 3.**
6. Use pencil to mark top edge of bracket location on post.
7. Dis-assemble the bracket by removing the barrel and screw. Reference the bracket options on page 32.
8. Place Bracket Base on previous top edge mark. Center the base on the post and use pencil to add marks for two screw hole locations. As shown in Fig. 4.

Note:

- Be sure bracket bases are centered on posts when marking hole locations.

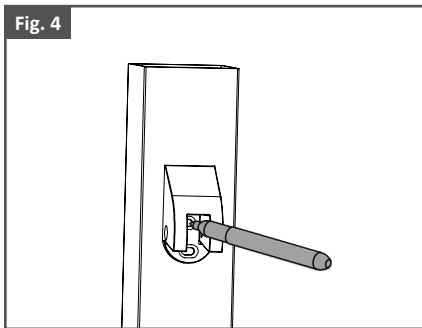
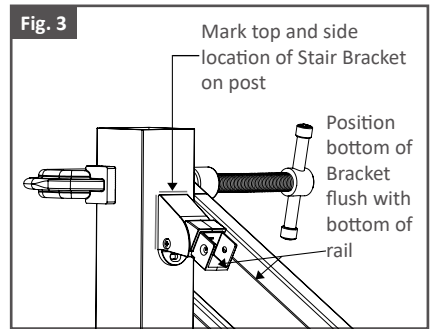
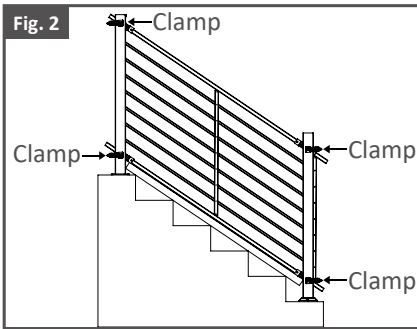
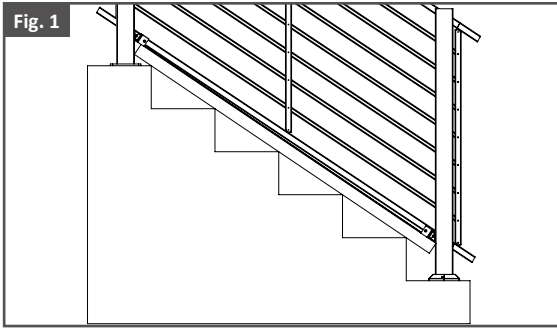

Step 4: Top Bracket Installation Continued

- Reference bottom bracket installation step 2 on pages 34 & 35.

Tip:

- For both top brackets (LT & ST), install the top screw first.

STAIR BRACKET: POST MOUNTING

- Reference Post Mounting instructions on page 5.

Note:

IT'S RECOMMENDED TO INSTALL BRACKETS ON TO POST BEFORE POST MOUNTING.

STAIR BRACKET: CUTTING DOWN PANELS (SSB-04 BRACKET)

Step 1: Determine The Top & Bottom Of Panel

1. Use the MDC Stamp to determine the bottom of the panel. The MDC Stamp can be found on the bottom inside face of the middle upright. As shown in Fig. 1.

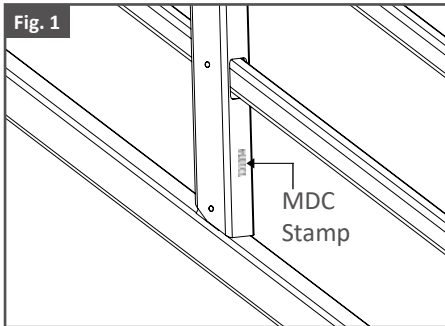

Step 2: Measure & Mark Panels Where Cuts Will Be Made

1. Position wood 2" x 4" [60mm x 102mm] on stairs in line with bottom brackets.
2. Place bottom rail of panel on top of wood 2" x 4" [60mm x 102mm] next to bottom brackets.
3. Panel needs to be positioned with middle upright centered between posts
4. Confirm that panel is level and uprights are parallel to posts, then clamp panel to posts.
5. Place reference markings on rails in line with the back of bracket opening. Be sure bottom of bracket and bottom of rail are flush. As shown in Fig. 1.
6. Unclamp the panel and place it on a flat surface, preferably a table.

7. From the reference marks, subtract 4" [102mm] and mark cut points on the top and bottom rails. As shown in Fig. 2.
8. Measure distance from rail cut mark to the end of the rail. As shown in Fig. 3. Write the dimension on paper for future reference.
9. Using a rubber mallet, remove one of the uprights from the panel. As shown in Fig. 4. **DO NOT** Remove the opposite upright.
10. Use previously found measurement (Fig. 3.) to mark picket cut points. Measure from the end of picket inward and mark the cut points. As shown in Fig. 5.
11. Place the removed upright on top of loose rails & pickets.
12. Position the back edge of upright in line with the previously marked rail reference marking and flush with the rails. As shown in Fig. 6.
13. **Confirm rail & picket cut marks before cutting the panel.**
14. Using a square, straighten cut point markings on top and side faces of rails and pickets. As shown in Fig. 7.

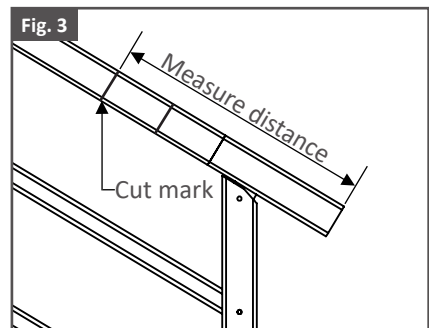
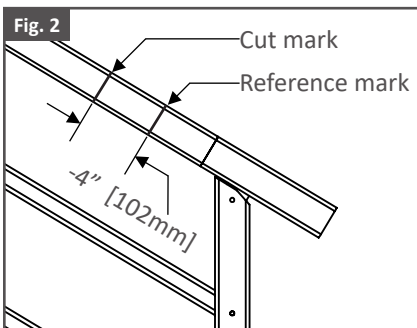
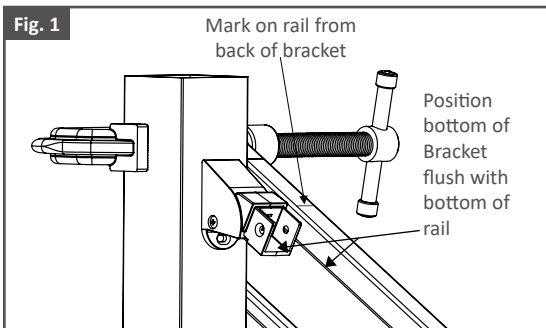

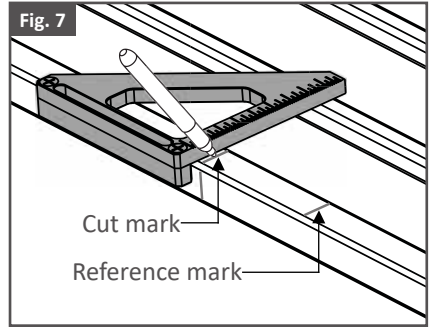
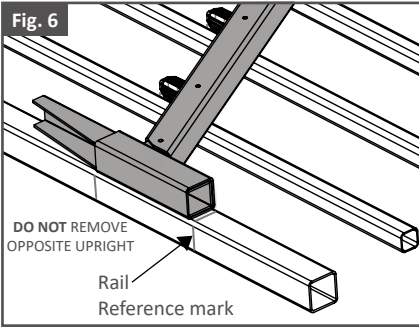
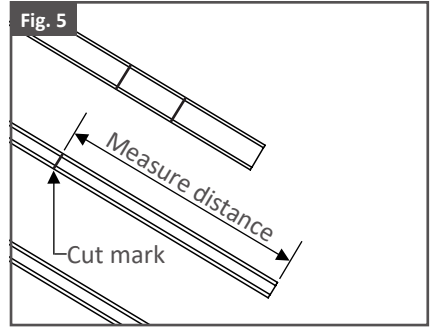
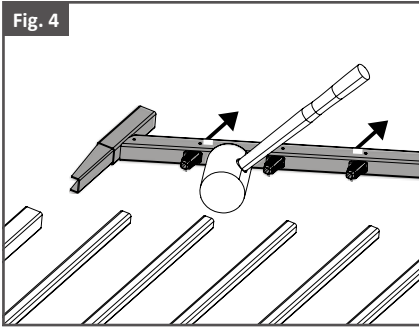

Step 3: Continue Stair Panel Cutting & Clean Steps

1. Reference steps 3 - 9 on pages 12 - 15 for the remaining panel cutting and cleaning steps.

STAIR BRACKET: PANEL INSTALLATION

- Reference panel installation steps on pages 15 - 17.

STAIR BRACKET: POST BASE COVER, BRACKET CAP & PRESSED DOME/BALL CAP INSTALLATION

- Reference Post Base Cover, Bracket Cap & Pressed Dome/ Ball Cap instructions on pages 17 - 19.

CARE & MAINTENANCE

Care And Maintenance Of Fortress Railing Products Powder-Coated Products And Surfaces:

- Immediately after installation of your Fortress Railing Products, clean powder-coated products and surfaces with a solution of warm water and non-abrasive, pH neutral detergent solution. Surfaces should be thoroughly rinsed after cleaning to remove all residues. All surfaces should be cleaned using a soft cloth or sponge.
- Ensure construction materials such as concrete, plaster, and paint splashes are removed immediately before they have a chance to dry. Failure to remove these materials may cause damage to the powder-coated surfaces.
- The frequency of cleaning depends in part on the standard of appearance and also the requirements to remove deposits that may cause damage to the powder coating after prolonged exposure. Fortress recommends cleaning in three to four monthly intervals all products and powder-coated surfaces. In areas where higher traffic, increased atmospheric substances, or other effects may occur, the time period between cleanings should be increased to monthly intervals.
- **WARNING: Do not use strong solvents such as thinners, or solutions containing chlorinated hydrocarbons, esters, or ketones. Abrasive cleaners or cutting compounds should not be used.**

WARRANTY

To obtain and review a copy of the warranty, please go to: <https://Fortressbp.com/warranties>. You can also contact: (844) 909-1999 or write to: Fortress Building Products Warranty, 1720 N 1st St, Garland, TX 75040 to obtain a copy of the warranty.



JOIN THE REVOLUTION.

FortressBP.com | 866.323.4766

© 2021 Fortress Building Products.

Unless otherwise noted, all proprietary names are trademarks of Fortress Iron, LP. All rights reserved.

03/2021