



## TEST REPORT

Rendered to:

**FORTRESS IRON RAILING & FENCE SYSTEMS**

For:

**Fortress Pre-Galvanized Steel Balusters**

*Vintage Series - Round and Square*

*Vienna Series - Belly*

**Report No: 89869.01-119-19**  
**Report Date: 05/22/09**

**TEST REPORT**

89869.01-119-19

May 22, 2009

---

**TABLE OF CONTENTS**

1.0 General Information.....	1
1.1 Product.....	1
1.2 Project Description .....	1
1.3 Limitations.....	1
1.4 Qualifications.....	1
1.5 Product Description .....	2
2.0 Structural Performance Testing of Assembled Railing Systems .....	2
2.1 Test Equipment.....	2
2.2 Test Setup .....	2
2.3 Test Procedure .....	3
2.4 Test Results.....	3
2.5 Summary and Conclusions .....	5
3.0 Closing Statement .....	6
Revision Log.....	7
Appendix A - Drawings	
Appendix B - Photographs	

## **TEST REPORT**

Rendered to:

FORTRESS IRON RAILING & FENCE SYSTEMS  
P.O. Box 831268  
Richardson, Texas 75083

Report No.: 89869.01-119-19  
Test Date Started: 03/31/09  
Test Date Completed: 04/01/09  
Report Date: 05/22/09

### **1.0 General Information**

#### **1.1 Product**

Fortress Pre-Galvanized Steel Balusters - *Vintage Series and Vienna Series*

#### **1.2 Project Description**

Architectural Testing was contracted by Fortress Iron Railing & Fence Systems to conduct structural performance tests on the following styles of pre-galvanized steel balusters: *Vintage Series Round (with EZ Mount)*, *Vintage Series Square*, and *Vienna Series Belly*. The system was evaluated for the design load requirements of the following building codes:

2006 *International Building Code*<sup>®</sup>, International Code Council

2006 *International Residential Code*<sup>®</sup>, International Code Council

Structural tests were performed according to Chapter 17 (Structural Tests and Special Inspections) of IBC 2006.

#### **1.3 Limitations**

All tests performed were to evaluate structural performance of the in-fill, pre-galvanized steel balusters, attached to 2x4 cedar railings. Testing is limited to in-fill testing only and to test loads equal to 2.5 times the design load.

#### **1.4 Qualifications**

Architectural Testing has demonstrated compliance with ANS/ISO/IEC Standard 17025 and is consequently accredited as a Testing Laboratory (TL-144) by International Accreditation Service, Inc.

## 1.5 Product Description

Fortress Iron Railing & Fence Systems provided the baluster test specimens and hardware with the following details:

Vintage Series Square Baluster: 5/8 in square by 31 in long, pre-galvanized steel square baluster with 0.05 in wall

Vintage Series Round Baluster: 3/4 in diameter by 32 in long, pre-galvanized steel round baluster with 0.05 in wall

Vienna Series Baluster: 1 in wide by 31 in long pre-galvanized steel, bent, flat bar baluster with 3/16 in wall

Vintage Series Square and Vienna Series Baluster Fasteners: #12 x 1-1/4 in flat-head, Phillips drive, wood screws (four total - two top and two bottom)

EZ Mount Round Baluster Connectors: #12 x 2 in stainless steel, flat-head, Phillips drive, wood screws with nylon standard EZ Mount (two per baluster)

Top and Bottom Rails: Cedar 2x4's with a measured moisture content of 12%

Architectural Testing provided the cedar 2x4 for the top and bottom rails mounted to pressure treated 4x4 wood posts. See drawings in Appendix A and photographs in Appendix B for additional details.

## 2.0 Structural Performance Testing of Assembled Railing Systems

### 2.1 Test Equipment

The guardrail was tested in a self-contained structural frame designed to accommodate anchorage of the guardrail assembly and application of the required test loads. The specimens were loaded using an electric winch mounted to a rigid steel test frame. High strength steel cables, nylon straps, and load distribution beams were used to impose test loads on the specimens. Applied load was measured using an electronic load cell located in-line with the loading system. Electronic linear motion transducers were used to measure deflections.

### 2.2 Test Setup

The 96 in wide by 33 in high guardrail assembly utilized for the *Vintage Series Square* and *Vienna Series* baluster systems were installed and tested as a single railing section by directly securing the wood 4x4 posts into a rigid steel test fixture, which rigidly restrained the posts from deflecting. A 96 in wide by 36 in high guardrail system was used for the *Vintage Series Round* baluster system. Transducers mounted to an independent reference frame were located to record movement of reference points on the guardrail system components (ends and mid-point) to determine net component deflections. See photographs in Appendix B for individual test setups.

## 2.3 Test Procedure

Each test specimen was inspected prior to testing to verify size and general condition of the materials, assembly, and installation. No potentially compromising defects were observed prior to testing. An initial load, not exceeding 50% of design load, was applied and transducers were zeroed. Load was then applied at a steady uniform rate until reaching 2.0 times design load in no less than 10 seconds. After reaching 2.0 times design load, the load was released. After allowing a minimum period of one minute for stabilization, load was reapplied to the initial load level used at the start of the loading procedure, and deflections were recorded and used to analyze recovery. Load was then increased at a steady uniform rate until reaching 2.5 times design load or until failure occurred. The testing time was continually recorded from the application of initial test load until the ultimate test load was reached.

## 2.4 Test Results

The following tests were performed on the guardrail assemblies for the design load requirements of the codes referenced. Deflection and permanent set were component deflections relative to their end-points; they were not overall system displacements. All loads and displacement measurements were horizontal, unless noted otherwise. Due to the irregular shape of the *Vienna Series* baluster, recovery was conservatively based on mid in-fill displacement.

### Key to Test Results Tables:

Load Level: Target test load

Test Load: Actual applied load at the designated load level (target). Where more than one value is reported, the test load was the range (min.-max.) that was held during the time indicated in the test.

Elapsed Time (E.T.): The amount of time into the test with zero established at the beginning of the loading procedure. Where more than one value is reported, the time was the range (start-end) that the designated load level was reached and sustained.

### Test Series No. 1 *Vienna Series*

Test No. 1 of 2 - 03/31/09					
Design Load: 50 lb / 1 Square Ft at Center of In-Fill (on Three Balusters)					
Load Level	Test Load (lb)	E.T. (min:sec)	In-Fill Displacement (in)		
			End	Mid	End
Initial Load	10	00:00	0.00	0.00	0.00
2.0x Design Load	100 - 104	00:27 - 00:30	0.28	0.90	0.02
Initial Load	10	02:02 - 02:12	0.00	0.14	0.76
85% Recovery from 2.0 x Design Load*					
2.5x Design Load	125 - 128	02:27 - 02:30	Achieved Load without Failure		

\* Due to the irregular shape of the baluster, recovery was conservatively based on mid in-fill displacement.

## 2.4 Test Results (Continued)

### Test Series No. 1 (Continued)

<b>Test No. 2 of 2 - 03/31/09</b>						
<b>Design Load: 50 lb / 1 Square Ft at Bottom of In-Fill (on Three Balusters)</b>						
Load Level	Test Load (lb)	E.T. (min:sec)	Bottom Rail Displacement (in)			
			End	Mid	End	Net <sup>1</sup>
Initial Load	10	00:00	0.00	0.00	0.00	0.00
2.0x Design Load	100 - 100	02:15 - 02:17	0.05	1.13	0.05	1.08
Initial Load	10 - 12	03:52 - 04:05	-0.01	0.00	-0.01	0.01
99% Recovery from 2.0 x Design Load						
2.5x Design Load	125 - 126	04:23 - 04:25	Achieved Load without Failure			

<sup>1</sup> Net displacement was the bottom rail displacement relative to its ends.

### Test Series No. 2 Vintage Series Square Baluster

<b>Test No. 1 of 2 - 04/01/09</b>						
<b>Design Load: 50 lb / 1 Square Ft at Center of In-Fill (on Three Balusters)</b>						
Load Level	Test Load (lb)	E.T. (min:sec)	In-Fill Displacement (in)			
			End	Mid	End	Net <sup>1</sup>
Initial Load	10	00:00	0.00	0.00	0.00	0.00
2.0x Design Load	100 - 101	00:13 - 00:16	0.23	0.49	0.62	0.07
Initial Load	10	02:03 - 02:13	0.01	0.02	0.02	0.01
82% Recovery from 2.0 x Design Load						
2.5x Design Load	126 - 128	02:31 - 02:44	Achieved Load without Failure			

<sup>1</sup> Net displacement was the infill displacement relative to its top and bottom.

<b>Test No. 2 of 2 - 04/01/09</b>						
<b>Design Load: 50 lb / 1 Square Ft at Bottom of In-Fill (on Three Balusters)</b>						
Load Level	Test Load (lb)	E.T. (min:sec)	Bottom Rail Displacement (in)			
			End	Mid	End	Net <sup>1</sup>
Initial Load	10	00:00	0.00	0.00	0.00	0.00
2.0x Design Load	100 - 102	00:11 - 00:17	0.03	0.78	0.05	0.74
Initial Load	10	02:23	0.00	0.01	0.00	0.01
99% Recovery from 2.0 x Design Load						
2.5x Design Load	126 - 129	03:00 - 03:08	Achieved Load without Failure			

<sup>1</sup> Net displacement was the bottom rail displacement relative to its ends.

## 2.4 Test Results (Continued)

### Test Series No. 3 *Vintage Series Round Baluster Installed with EZ Mounts*

Test No. 1 of 2 - 04/01/09						
Design Load: 50 lb / 1 Square Ft at Center of In-Fill (on Three Balusters)						
Load Level	Test Load (lb)	E.T. (min:sec)	In-Fill Displacement (in)			
			End	Mid	End	Net <sup>1</sup>
Initial Load	10	00:00	0.00	0.00	0.00	0.00
2.0x Design Load	100 - 104	00:13 - 00:33	0.12	0.33	0.17	0.18
Initial Load	10	02:18	0.00	0.01	0.00	0.01
96% Recovery from 2.0 x Design Load						
2.5x Design Load	125 - 127	02:48 - 03:00	Achieved Load without Failure			

<sup>1</sup> Net displacement was the infill displacement relative to its top and bottom.

Test No. 2 of 2 - 04/01/09						
Design Load: 50 lb / 1 Square Ft at Bottom of In-Fill (on 3 Balusters)						
Load Level	Test Load (lb)	E.T. (min:sec)	Bottom Rail Displacement (in)			
			End	Mid	End	Net <sup>1</sup>
Initial Load	10	00:00	0.00	0.00	0.00	0.00
2.0x Design Load	102 - 105	00:15 - 00:31	0.01	0.26	0.02	0.25
Initial Load	10 - 11	02:41 - 03:12	0.00	0.00	-0.01	0.01
97% Recovery from 2.0 x Design Load						
2.5x Design Load	126 - 129	03:32 - 03:43	Achieved Load without Failure			

<sup>1</sup> Net displacement was the bottom rail displacement relative to its ends.

## 2.5 Summary and Conclusions

Using performance criteria of 75% deflection recovery from 2.0 times design load and withstanding an ultimate load of 2.5 times design load, the test results substantiate compliance with the design load requirements of the referenced building codes for the 96 in wide by 36 in high railing assembly containing the *Vintage Series Round* style balusters and for the 96 in wide by 33 in high railing assembly containing the *Vienna Series* and *Vintage Series Square* style balusters reported herein.

### 3.0 Closing Statement

Detailed drawings, data sheets, representative samples of test specimens, a copy of this test report, and all other supporting evidence will be retained by Architectural Testing for a period of four years from the original test date. At the end of this retention period, said materials shall be discarded without notice, and the service life of this report by Architectural Testing shall expire. Results obtained are tested values and were secured using the designated test methods. This report neither constitutes certification of this product nor expresses an opinion or endorsement by this laboratory; it is the exclusive property of the client so named herein and relates only to the tested specimens. This report may not be reproduced, except in full, without the written approval of Architectural Testing.

For ARCHITECTURAL TESTING:

---

Julia L. Allison  
Technician II  
Structural Systems Testing

---

Justin M. Mann  
Laboratory Supervisor  
Structural Systems Testing

JMM:jmm/alb

Attachments (pages): This report is complete only when all attachments listed are included.

Appendix A: Drawings (3)

Appendix B: Photographs (5)



### Revision Log

<u>Rev. #</u>	<u>Date</u>	<u>Page(s)</u>	<u>Revision(s)</u>
0	05/22/09	N/A	Original report issue

**APPENDIX A**

**Drawings**



# Architectural Testing

Test sample complies with these details.  
Deviations are noted.

Report# 89869.01-119-A

Date 5/22/09 Tech JLA

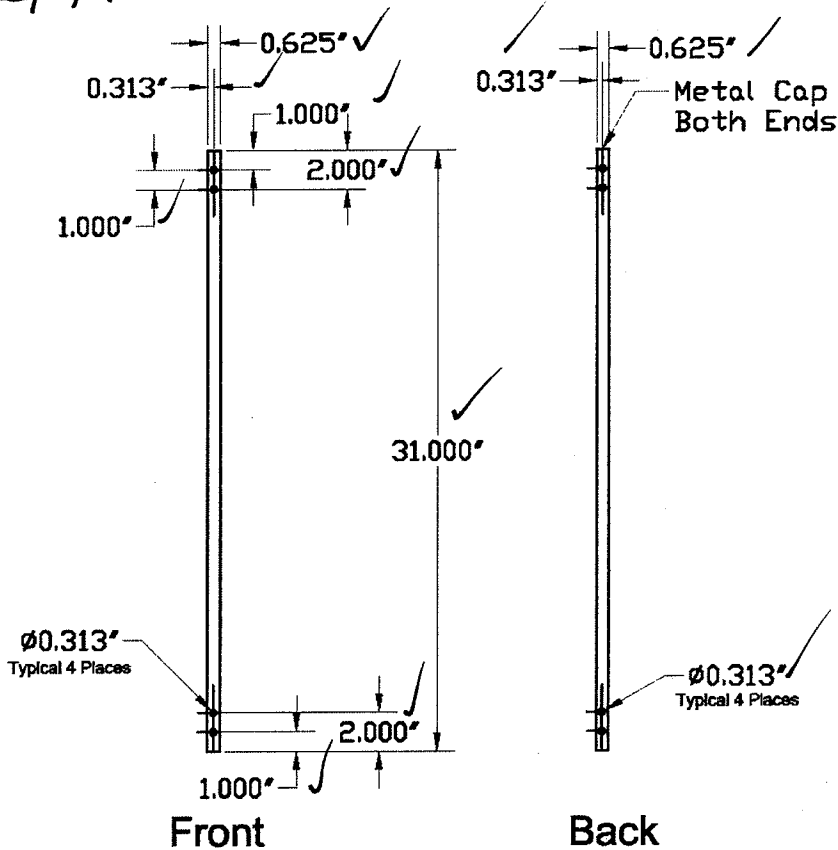

### Notes:

1. Materials are Galvanized, G60 Sheet, 45,000psi, formed and welded full length
2. Tube welds are ground or scrapped smooth with no sharp edges or points and zinc thermal sprayed
3. After cutting to length product is cleaned then either Zinc Phosphate Washed or Dipped, then powder coated.

This drawing and the information contained on this drawing are the property of Fortress Iron, LP, Richardson, Texas, USA, and is not to be copied electronically or manually, or reproduced in any manner, or divulged to other sources, without the expressed written permission of an authorized representative of Fortress Iron L.P.



Fortress Iron, LP  
1800 Jay Ell, Suite 200  
Richardson, TX 75081

0	03/10/06	DI	Initial Drawing Generation
REV	DATE	BY	DESCRIPTION
TITLE Square Baluster			
31 Inch Square Baluster, Plain			
DRAWN BY	David Irick	SCALE	As Shown
DATE	03/09/06		
DWG NAME	31" Square Baluster	REV.	0



# Architectural Testing

Test sample complies with these details.  
Deviations are noted.

Report# 89869.01-119-19

Date 5/22/09 Tech JLA

### Notes:

1. Materials are formed sheet, 45,000psi.
2. After cutting and shaping to size product is zinc electroplated then cleaned, given a zinc phosphate coating, and powder coated.

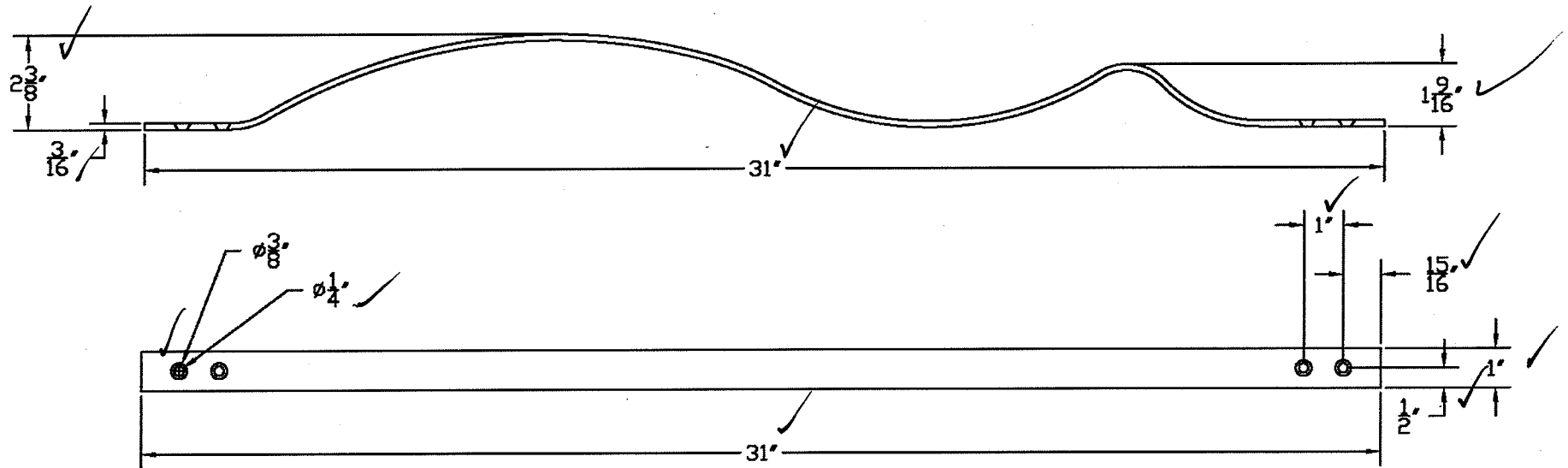

This drawing and the information contained on this drawing are the property of Fortress Iron, LP, Richardson, Texas, USA, and is not to be copied electronically or manually, or reproduced in any manner, or divulged to other sources, without the expressed written permission of an authorized representative of Fortress Iron L.P.



Fortress Iron, LP  
1800 Jay Ell, Suite 200  
Richardson, TX 75081

0	02/03/07	DI	Initial Drawing Generation
REV	DATE	BY	DESCRIPTION
TITLE: Vienna Belly Baluster			
31" Belly Baluster			
DRAWN BY: David Irick			SCALE: As Shown
DATE: 02/03/07			
DWG. NO.: 31" Vienna Belly Baluster			REV: 0



# Architectural Testing

Test sample complies with these details.  
Deviations are noted.

Report# 89869.01-19-19

Date 5/22/09 Tech JLA

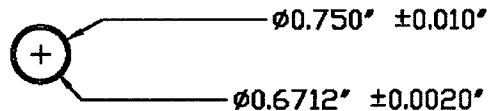
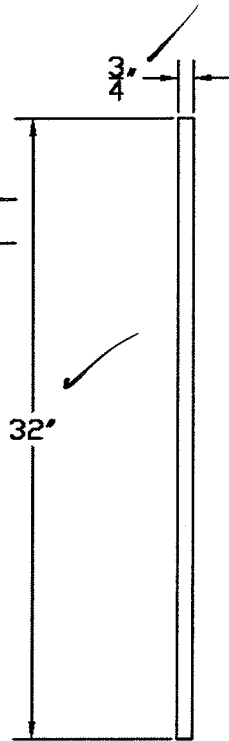

Picket End View - Scale 4X

Note: Picket OD varies based on powder coating type and with manufacturing runs.

Picket ID varies based on manufacturing runs and based on amount of powder coating inside picket.

### Notes:

1. Materials are Galvanized, G60 Sheet, 45,000psi, formed and welded full length
2. Tube welds are ground or scrapped smooth with no sharp edges or points and zinc thermal sprayed
3. After cutting to length product is cleaned then either Zinc Phosphate Washed or Dipped, then powder coated.

This drawing and the information contained on this drawing are the property of Fortress Iron, LP, Richardson, Texas, USA, and is not to be copied electronically or manually, or reproduced in any manner, or divulged to other sources, without the expressed written permission of an authorized representative of Fortress Iron L.P.



Fortress Iron, LP  
1800 Jay Ell, Suite 200  
Richardson, TX 75081

0		07/13/06	DI	Initial Drawing Generation
REV	DATE	BY	DESCRIPTION	
TITLE Round Baluster				
32 Inch Round Baluster, Plain				
DRAWN BY David Irick			SCALE As Shown	
DATE 07/13/06			REV. 0	
DWG NAME DRAWING FILE			32" Round Baluster	

**APPENDIX B**

**Photographs**



**Photo No. 1**  
**In-Fill Load Test at Center of Three *Vienna Series* Balusters**

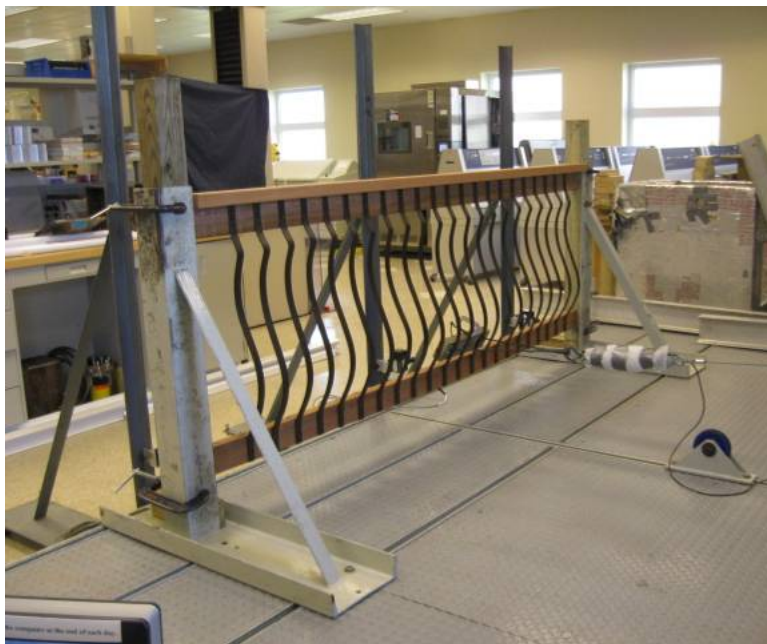

**Photo No. 2**  
**In-Fill Load Test at Bottom of Three *Vienna Series* Balusters**

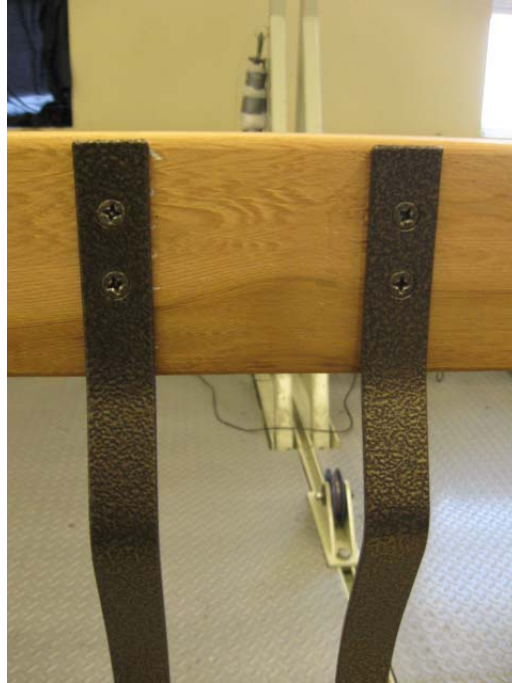

**Photo No. 3**  
***Vienna Series* Baluster Installation (4 in On-Center Spacing)**



**Photo No. 4**  
**In-Fill Load Test at Center of Three *Vintage Series* Square Style Balusters**





**Photo No. 5**  
**In-Fill Load Test at Bottom of Three *Vintage Series Square* Style Balusters**



**Photo No. 6**  
***Vintage Series Square* Baluster Installation (4 in On-Center Spacing)**



**Photo No. 7**  
**In-Fill Load Test at Center of Three *Vintage Series Round Style* Balusters**  
**(Installed with EZ Mounts)**



**Photo No. 8**  
**In-Fill Load Test at Bottom of Three *Vintage Series Round Style* Balusters**  
**(Installed with EZ Mounts)**



**Photo No. 9**  
**Nylon EZ Mounts for Attachment of**  
***Vintage Series Round Style Balusters* to Rails**



**Photo No. 10**  
***Vintage Series Round Style Baluster* and**  
**Nylon EZ Mounts - Installation to Top Rail**